

## Operating, Maintenance & Parts Manual

# JLCMT Series



### Model Numbers

**JLCMT0232**

**JLCMT0516**

**JLCMT0532**

**JLCMT1016**

**JLCMT1032**

**JLCMT2016**

**JLCMT4008**

**Follow all instructions and warnings for inspecting, maintaining and operating this hoist.**

The use of any hoist presents some risk of personal injury or property damage. That risk is greatly increased if proper instructions and warnings are not followed. Before using this hoist, each operator should become thoroughly familiar with all warnings, instructions, and recommendations in this manual. Retain this manual for future reference and use.

Forward this manual to the hoist operator. Failure to operate the equipment as directed in the manual may cause injury.

Should you have any questions regarding this product, please call Coffing Hoists at **(800) 477-5003**.

**Made in U.S.A.**

Before using the hoist, fill in the information below:

Model No. \_\_\_\_\_

Serial No. \_\_\_\_\_

Purchase Date \_\_\_\_\_

### UNPACKING

The electric chain hoist and motorized trolley are fully assembled. If possible, lift the unit out of the box by hoisting it up by the trolley. Do not pull it up by the hoist motor and housing. Damage could result.

After unpacking the unit, carefully inspect for any damage that may have occurred during transit. Check for loose, missing or damaged parts. Shipping damage claims must be filed with the carrier. Be sure that the voltage labeled on the unit matches your power supply.

# COFFING®

## HOISTS

## SAFETY PRECAUTIONS

Each Coffing JLCMT Series Electric Chain Hoist is built in accordance with the specifications contained herein and at the time of manufacture complies with our interpretation of applicable sections of \*American Society of Mechanical Engineers Code (ASME) B30.16 "Overhead Hoists," the National Electrical Code (ANSI/NFPA 70) and the Occupational Safety and Health Act (OSHA). Since OSHA states the National Electrical Code applies to all electric hoists, installers are required to provide current overload protection and grounding on the branch circuit section in keeping with the code. Check each installation for compliance with the application, operation and maintenance sections of these articles.

\*Copies of this Standard can be obtained from ASME Order Department, 22 Law Drive, PO Box 2300, Fairfield, NJ 07007-2300, U.S.A. [www.asme.org](http://www.asme.org), 800-843-2763

### **WARNING**

**Improper operation of a hoist can create a potentially hazardous situation which, if not avoided, could result in death or serious injury. To avoid such a potentially hazardous situation, THE OPERATOR SHALL:**

1. **NOT** operate a damaged, malfunctioning or unusually performing hoist.
2. **NOT** operate the hoist until you have thoroughly read and understood the manufacturer's Operating and Maintenance Instructions or Manuals.
3. **NOT** operate a hoist which has been modified without the manufacturer's approval or without certification that it is in conformity with ANSI/ASME B30 volumes.
4. **NOT** lift more than rated load for the hoist.
5. **NOT** use hoist with twisted, kinked, damaged, or worn load chain.
6. **NOT** use the hoist to lift, support, or transport people.
7. **NOT** lift loads over people.
8. **NOT** operate a hoist unless all persons are and remain clear of the supported load.
9. **NOT** operate unless load is centered under hoist.
10. **NOT** attempt to lengthen the load chain or repair damaged load chain.
11. Protect the hoist's load chain from weld splatter or other damaging contaminants.
12. **NOT** operate hoist when it is restricted from forming a straight line from hook to hook in the direction of loading.
13. **NOT** use load chain as a sling, or wrap chain around load.
14. **NOT** apply the load to the tip of the hook or to the hook latch.
15. **NOT** apply load unless load chain is properly seated in the chain sprocket(s).
16. **NOT** apply load if bearing prevents equal loading on all load supporting chains.
17. **NOT** operate beyond the limits of the load chain travel.
18. **NOT** leave load supported by the hoist unattended unless specific precautions have been taken.
19. **NOT** allow the load chain or hook to be used as an electrical or welding ground.

20. **NOT** allow the load chain or hook to be touched by a live welding electrode.
21. **NOT** remove or obscure the warnings on the hoist.
22. **NOT** operate a hoist on which the safety placards or decals are missing or illegible.
23. **NOT** operate a hoist unless it has been securely attached to a suitable support.
24. **NOT** operate a hoist unless load slings or other approved single attachments are properly sized and seated in the hook saddle.
25. Take up slack carefully - make sure load is balanced and load holding action is secure before continuing.
26. Shut down a hoist that malfunctions or performs unusually and report such malfunction.
27. Make sure hoist limit switches function properly.
28. Warn personnel of an approaching load.

### **CAUTION**

**Improper operation of a hoist can create a potentially hazardous situation which, if not avoided, could result in minor or moderate injury. To avoid such a potentially hazardous situation, THE OPERATOR SHALL:**

1. Maintain firm footing or be otherwise secured when operating the hoist.
2. Check brake function by tensioning the hoist prior to each lift operation.
3. Use hook latches. Latches are to retain slings, chains, etc. under slack conditions only.
4. Make sure the hook latches are closed and not supporting any parts of the load.
5. Make sure the load is free to move and will clear all obstructions.
6. Avoid swinging the load or hook.
7. Make sure hook travel is in the same direction as shown on the controls.
8. Inspect the hoist regularly, replace damaged or worn parts, and keep appropriate records of maintenance.
9. Use Coffing Hoists recommended parts when repairing the unit.
10. Lubricate load chain per hoist manufacturer's recommendations.
11. **NOT** use the hoist's overload limiting clutch to measure load.
12. **NOT** use limit switches as routine operating stops. They are emergency devices only.
13. **NOT** allow your attention to be diverted from operating the hoist.
14. **NOT** allow the hoist to be subjected to sharp contact with other hoists, structures, or objects through misuse.
15. **NOT** adjust or repair the hoist unless qualified to perform such adjustments or repairs.

## TABLE OF CONTENTS

|   |            |
|---|------------|
| Safety Precautions .....                    | 2          |
| Hoist Specifications .....                  | 3          |
| Application Information .....               | 3          |
| Safety Information .....                    | 5          |
| Installation .....                          | 5          |
| Operation .....                             | 7          |
| Maintenance .....                           | 8          |
| Wiring Diagrams .....                       | 18         |
| Trouble Shooting .....                      | 22         |
| Inspection and Maintenance Check List ..... | 24         |
| Recommended Lubrication Schedule .....      | 25         |
| Replacement Parts List .....                | 26         |
| Parts Depot & Warranty Repair Centers ..... | 48         |
| Warranty .....                              | Back Cover |

## HOIST SPECIFICATIONS

Coffing JLCMT hoist models are essential tools in material handling. They provide quick and precise lifting with the added versatility of a motorized trolley. The hoists are available in various lifting speeds and capacities up to 2 tons. The motorized trolley is available in a range of speeds, from 18 fpm to 150 fpm (35 fpm standard), and negotiates curves down to 4 feet in radius. The operator single handedly controls the position of the unit and the lifting of loads with an ergonomically designed pushbutton station. For more precise control, 3-phase units are also available with 2-speed motors. JLCMT hoist and trolley units are available for a number of 1-phase and 3-phase voltages. The control circuitry is of a low voltage-24V is standard, 115V is optional.

The hoist has an oil filled gearbox equipped with alloy steel gears for smooth and durable operation. An overload clutch protects the unit from damaging overloads. Adjustable upper and lower limit switches regulate the load travel, and a chain-stop on the slack end of the chain serves as an extra measure of safety. A magnetic disc brake delivers sure stopping and secure holding of the load. The chain and hooks on a Coffing hoist are specifically made for the demands of hoist applications. Safety latches are standard on the hooks.

The trolley rolls on heat-treated, cast iron wheels with sealed ball bearings. The worm driven transmission provides even starting and stopping. JLCMT units can be adjusted to fit beam flange widths in the range of 3.33 to 7 inches, and as an option can be made to fit up to a 9 inch width.

Coffing electric chain hoists with motorized trolleys are designed and tested (fully assembled) in accordance with the American Society of Mechanical Engineers Code B30.16, "Safety Standard for Overhead Hoists." Made in U.S.A.

### **WARNING**

**Failure to comply with Safety Precautions outlined throughout this manual can result in serious injuries or death. Before using this hoist, each operator should become thoroughly familiar with all warnings, instructions and recommendations in this manual.**

## APPLICATION INFORMATION

### GENERAL INFORMATION

This manual provides information for the safe operation, installation, and maintenance of Coffing JLCMT models. Any person operating or maintaining this hoist must be familiar with the information contained herein. Adherence to the precautions, procedures, and maintenance practices described in this manual should ensure long reliable operation.

This hoist is intended for general industrial use for lifting and transporting freely suspended material loads within its rated capacity. Coffing Hoists cannot be responsible for applications other than those for which Coffing equipment is recommended. Prior to installation and operation, we caution the user to review his application for abnormal environmental or handling conditions and to observe the applicable recommendations as follows:

### ADVERSE ENVIRONMENTAL CONDITIONS

Do not use the hoist in areas containing flammable vapors, liquids, gases or any combustible dusts or fibers. Refer to Article 500 of the National Electrical Code. Do not use this hoist in highly corrosive, abrasive or wet environments. Do not use this hoist in applications involving extended exposure to ambient temperatures below -10°F or above 130°F.

### LIFTING OF HAZARDOUS LOADS

This hoist is not recommended for use in lifting or transporting hazardous loads or materials which could cause widespread damage if dropped. The lifting of loads which could explode or create chemical or radioactive contamination if dropped requires fail-safe redundant supporting devices which are not incorporated into this hoist.

## Figure 1 - Specifications and Dimensions

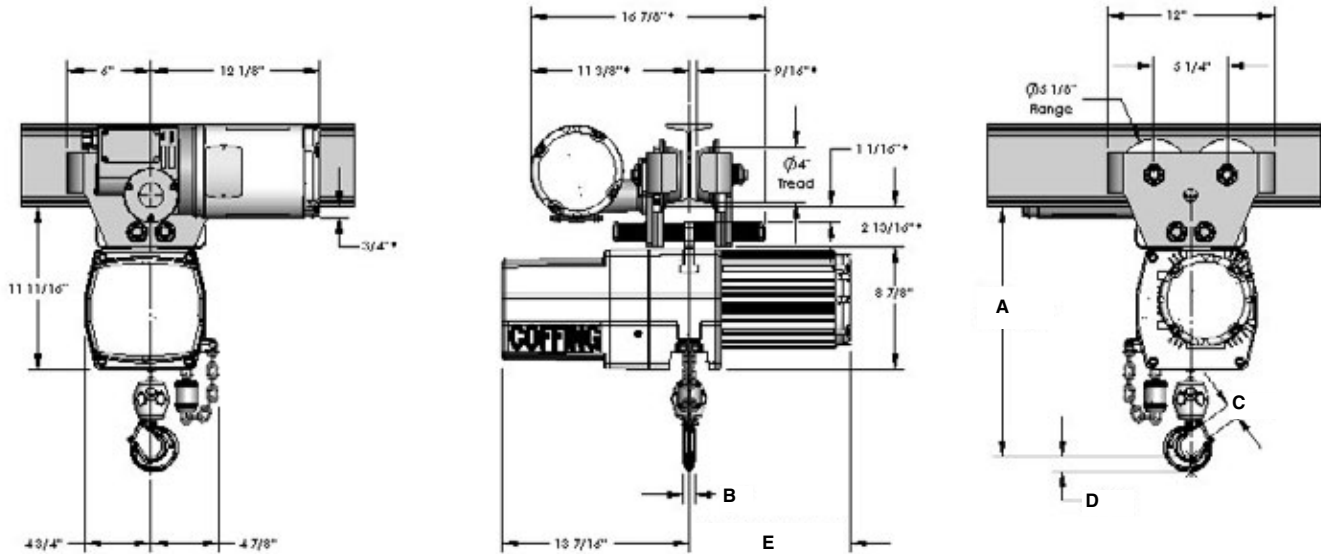

**NOTE:** All dimensions are inches. Dimensions marked \* are based on S6 x 12.5 beam. Headroom dimension A includes 2 inch clearance.

**Table 1 — Hoist Specifications**

| Model     | Capacity<br>Capacity<br>(lbs) | Lifting<br>Speed<br>(fpm) | Hoist<br>HP** | Dimensions                       |       |       |                                | Dimension "E" **                 |                                  |                                 |
|-----------|-------------------------------|---------------------------|---------------|----------------------------------|-------|-------|--------------------------------|----------------------------------|----------------------------------|---------------------------------|
|           |                               |                           |               | A                                | B     | C     | D                              | 1-Phase                          | 1-Speed<br>3-Phase               | 2-Speed<br>3-Phase              |
| JLCMT0232 | 250                           | 32                        | 1/4           | 17 <sup>15</sup> / <sub>16</sub> | 7/8   | 1     | 1 <sup>1</sup> / <sub>16</sub> | 10 <sup>11</sup> / <sub>16</sub> | 10 <sup>11</sup> / <sub>16</sub> | 11 <sup>9</sup> / <sub>16</sub> |
| JLCMT0516 | 500                           | 16                        | 1/2           | 17 <sup>15</sup> / <sub>16</sub> | 7/8   | 1     | 1 <sup>1</sup> / <sub>16</sub> | 10 <sup>11</sup> / <sub>16</sub> | 10 <sup>11</sup> / <sub>16</sub> | 11 <sup>9</sup> / <sub>16</sub> |
| JLCMT0532 | 500                           | 32                        | 1/2           | 17 <sup>15</sup> / <sub>16</sub> | 7/8   | 1     | 1 <sup>1</sup> / <sub>16</sub> | 10 <sup>11</sup> / <sub>16</sub> | 10 <sup>11</sup> / <sub>16</sub> | 11 <sup>9</sup> / <sub>16</sub> |
| JLCMT1016 | 1000                          | 16                        | 1/2           | 17 <sup>15</sup> / <sub>16</sub> | 7/8   | 1     | 1 <sup>1</sup> / <sub>16</sub> | 10 <sup>11</sup> / <sub>16</sub> | 10 <sup>11</sup> / <sub>16</sub> | 11 <sup>9</sup> / <sub>16</sub> |
| JLCMT1032 | 1000                          | 32                        | 1             | 17 <sup>15</sup> / <sub>16</sub> | 7/8   | 1     | 1 <sup>1</sup> / <sub>16</sub> | 10 <sup>11</sup> / <sub>16</sub> | 10 <sup>11</sup> / <sub>16</sub> | 11 <sup>9</sup> / <sub>16</sub> |
| JLCMT2016 | 2000                          | 16                        | 1             | 17 <sup>15</sup> / <sub>16</sub> | 7/8   | 1     | 1 <sup>1</sup> / <sub>16</sub> | 10 <sup>11</sup> / <sub>16</sub> | 10 <sup>11</sup> / <sub>16</sub> | 11 <sup>9</sup> / <sub>16</sub> |
| JLCMT4008 | 4000                          | 8                         | 1             | 20 <sup>5</sup> / <sub>8</sub>   | 15/16 | 1 1/8 | 1 1/4                          | 10 <sup>11</sup> / <sub>16</sub> | 10 <sup>11</sup> / <sub>16</sub> | 11 <sup>9</sup> / <sub>16</sub> |

**Table 2 — Motorized Trolley Specifications**

| Model                                    | Trolley HP** | Dimension "F" **               |                               |                                |
|--|--------------|--------------------------------|-------------------------------|--------------------------------|
|  |              | 1-Phase                        | 1-Speed<br>3-Phase            | 2-Speed<br>3-Phase             |
| All Models (except below)                | 1/4          | 10 <sup>3</sup> / <sub>8</sub> | 9 <sup>3</sup> / <sub>8</sub> | 11 <sup>3</sup> / <sub>8</sub> |
| JLCMT4008 with 100<br>or 150 fpm Trolley | 1/2          | 10 <sup>3</sup> / <sub>8</sub> | 9 <sup>3</sup> / <sub>8</sub> | 11 <sup>7</sup> / <sub>8</sub> |

**Standard Trolley Speed:** 35 fpm; **Optional Speeds:** 18, 24, 50, 75, 100 or 150 fpm (The slow speed for 2-speed trolleys is 1/3 of the top speed; i.e., 75 fpm trolley has a slow speed of 25 fpm).

**Beam Width Adjustment Range:** 3.33 to 7 inches standard, up to 9 inches optional (As an option, trolleys are also available to work with patented track).

\*\*Note: Hoist and trolley horsepower can vary from what is listed, which can also affect dimensions "E" and "F". Refer to the motor nameplates on the hoist and trolley for specific information on the supplied motors.

## SAFETY INFORMATION

For safe use of the electric chain hoist and motorized trolley, adherence to the following precautions is imperative. All persons concerned with the installation, operation, inspection and maintenance of the hoist and trolley are urged to read the American Society of Mechanical Engineers (ASME) Safety Code B30.16, "Overhead Hoists (Underhung)."

1. Follow all local electrical and safety codes, as well as the National Electrical Code (NEC) and the Occupational Safety and Health Act (OSHA) in the United States.
2. Before installing the hoist and trolley unit, be sure that the beam and the supporting structure have adequate strength for the capacity of the hoist. If in doubt, consult a qualified structural engineer.
3. Open-ended beams must have end stops to prevent the trolley from running off the beam. In the event of a collision, the stops should only contact the side plate bumpers.
4. The hoist and trolley must be adequately grounded. The power and ground connections are made at the trolley motor junction box (green wire is ground), or if supplied, the trolley control box.
5. Make certain that the power source conforms to the requirements of your equipment.
6. Three-phase power connections must be made such that the hoist runs in the correct direction when pushing the "UP" or "DOWN" buttons (See ELECTRICAL CONNECTIONS, page 6).
7. Power must be supplied to the unit in a manner that will ensure that power cables, if used, do not develop kinks or come in harms way. Do not allow cables to come in contact with oil, grease, hot surfaces or chemicals.
8. The hoist and trolley are designed for vertical lifting only. Loads should be located directly under the hoist. Side loading can damage the unit as well as endanger life and limb.
9. Do not lift loads in excess of the rated capacity.
10. Do not use the hoist and trolley to lift and transport people or to move loads over people. Stand clear when lifting a load and be sure that all personnel are clear and aware before moving a load in their area.
11. The operator should have a clear view of the load anytime it is moving and should be sure that the load does not contact any obstructions. Never leave a suspended load unattended.
12. Always allow the trolley to coast to a stop in the direction of travel before reversing its direction. Reversing or "plugging" to stop the trolley causes overheating of the trolley motor and causes the load to sway.
13. Inspect the unit daily before operating the hoist.
14. Cluttered areas and benches invite accidents.
15. The operator should not engage in any practice which will divert his attention while operating the hoist.
16. Do not attempt to operate hoist beyond normal maximum lift range.
17. Do not operate hoist with twisted or damaged chain.

18. Do not operate a damaged or malfunctioning hoist until necessary adjustments or repairs have been made.
19. Always remove load before making repairs.
20. Do not remove or obscure capacity or warning decals.

### **WARNING**

**Always disconnect power source before working on or near a hoist or its connected load. If the power disconnect point is out of sight, lock it in the open position and tag to prevent unexpected application of power.**

## INSTALLATION

1. Before installing the hoist and trolley, review and adhere to the following precautions.
  - a. Be sure that the beam and the supporting structure have adequate strength for the capacity of the hoist. If in doubt, consult a qualified structural engineer.
  - b. Provide proper branch circuit protection for the hoist as recommended in the National Electrical Code.
  - c. The power supply voltage should be within plus or minus 10% of the voltage for which the unit is wired. **Refer to the hoist and trolley motor nameplates for information on the full load amperage.** It is critical to use adequate sized power cables, especially with 1-phase hoists (See **Table 4, page 14**). Be sure dual voltage hoists are connected or wired to correspond with your power supply (See ELECTRICAL CONNECTIONS, page 6).
  - d. The installation area must provide operating conditions for the operator including sufficient room for the operator and other personnel to stand clear of the load at all times.
  - e. For installations where the slack chain hanging from the unit may be objectionable or hazardous, the use of a chain container is recommended. See CHAIN CONTAINER, pages 6 & 7.

### INITIAL LUBRICATION

Lubricate the trolley wheel gears with NLGI-2 or heavier grease. Hoists are shipped with the load chain prelubricated. If necessary, apply SAE 90 gear oil.

### TROLLEY MOUNTING TO BEAM

Refer to Figure 11.

1. Coffing JLCMT models are designed to fit beam flange widths in the range of 3.00 to 7" as a standard. Wider beams up to 9" and patented track beams can be fit with optional load pins and/or wheels. Be sure that the flange width of the runway beam is within the adjustment range.

The unit is shipped assembled with the trolley set for a flange width of 3.33" unless otherwise specified when ordering. If adjustment is required, place the hoist and trolley unit onto a worktable and follow the steps below. Be sure that power is not connected to the unit.

  - a. Adjusting to a particular beam size is accomplished by locating the thick (.135") and thin (.075") washers as shown (See Figure 11, page 16). Begin by removing the load pin nuts on the plain side of the trolley (1 1/16" wrench

or socket required). If necessary a pry bar can be used between the load pins to prevent the pins from turning with the nuts. Slide the washers off the load pins, keeping the washers for each load pin stacked separately. Slide the side plate off of the load pins. Remove the remaining washers on the plain side of the trolley and stack them separately for each load pin.

- b. Carefully pull the trolley transmission with the attached side plate assembly away from the suspension lug. Be careful not to pull on the tie cable. Remove the exposed washers on the two load pins and stack them separately for each load pin. Lay the assembly upside down to where the load pin nuts can be accessed. Remove the two elastic stop nuts with a 1<sup>1</sup>/<sub>16</sub>" wrench and a vise grip to hold the pins.
  - c. From Figure 11 determine how many spacer washers of each thickness are required on the outside of the side plates (Locations B) and on the inside of the side plates (Locations A) for each load pin. The chart is an approximate guide. Flange widths will vary, so it is important to measure the beam flange to be sure of its width. Slight changes to the recommended washer distribution may be required. When the trolley is set correctly, the distance between the wheel flanges will exceed the beam flange width by 1/4" to 7/16" (See Figure 11).
  - d. Reassemble with the correct placement of spacer washers. Be sure to put the load pins, washers and nuts on the transmission side plate first. At this point, do not tighten the load pin nuts on the plain side plate. Be sure that all four "Locations A" have an equal number of thick and thin washers (See Figure 11). Once together, the width adjustment must be double-checked before tightening the nuts completely in the following steps.
2. **For mounting to a beam that is not open ended**, leave off the outside washers on the plain side plate and turn the two nuts onto the load pins just enough to prevent the side plate from falling off. Slide the plain side plate out enough to allow the wheels to clear the beam flange. Carefully position the hoist and trolley unit to where the wheels are over the flange and pull the side plates together. Ensure that the plates do not separate as you remove the load pin nuts on the plain side plate, replace the outside spacer washers, and reinstall the nuts. Tighten the load pin nuts to **100 ft-lbs**. A pry bar may be used between the load pins to prevent them from turning as the nuts are tightened.
  3. **For mounting to an open-ended beam with rail stops**, first tighten the load pin nuts to **100 ft-lbs**. If necessary, use a pry bar between the load pins to prevent the pins from rotating as the nuts are tightened. With the rail stop removed at the end of the beam, position the hoist and trolley so that the trolley can slide onto the beam. Reinstall the rail stop on the end of the beam.

## ELECTRICAL CONNECTIONS

Refer to Figures 11 & 12A-12F.

1. Disconnect and lock out power before making connections.
2. Ensure that the hoist and trolley are built and wired for the intended voltage. Single-phase units have dual-voltage motors and components designed for use on 115V or 230V when wired correctly. Similarly, 1-speed hoist/1-speed trolley units made for 230/460V must be wired for intended voltage. Refer to the wiring diagram that is supplied with the unit. Figures 12A - 12F are diagrams for standard units.
3. Single-phase units (115/230V) are shipped wired for 115V unless otherwise specified. Dual voltage 230/460V units are wired for 460V as a standard. Units that have a 2-speed hoist and/or 2-speed trolley are for one voltage only, as can be found on the nameplate of the 2-speed motor. Make voltage conversions on 115/230V or 230/460V models as follows:
  - a. Remove the electrical cover on the hoist. Rewire per the "Motor and Brake Connections" on the wiring diagram.
  - b. Connect the transformer lead, "H2" or "H4", to the trolley contactor according to the voltage. Be sure to insulate the terminal on the spare transformer lead.
  - c. Access the trolley motor connections by removing the splice plate (See Figure 11). Disconnect the existing splice connections and rewire per the splice connection chart on the wiring diagram.
4. The power connection is made at the trolley motor junction box, or, if provided, a trolley control box. If connecting to the junction box, remove and discard the plug to allow the power cord to enter, and remove the splice plate to make the power connections. Be sure to make the ground connection.
5. Turn on the power. On 3-phase models, push the "UP" button and observe the direction of travel of the load block. If it raises, the phasing is correct and permanent connections may be made at the power source. If the load block lowers when the "UP" button is pushed, release the button immediately since the limit switches will not operate to protect the hoist from over-travel. Reverse any two wires (except the green ground wire) at the power source to correct the load hook direction (phasing). Do not change connections in the hoist or pushbutton assembly.
6. Before placing the hoist into operation, check the limit switch adjustment. See LIMIT SWITCH ADJUSTMENT, page 10.

## CHAIN CONTAINER (Optional Accessory)

Refer to Table 3.

For installations where the slack chain hanging from the hoist may be objectionable or hazardous, the use of a chain container is recommended.

### **WARNING**

**Always disconnect power source before working on or near a hoist or its connected load. If the power disconnect point is out of sight, lock it in the open position and tag to prevent unexpected application of power.**

### **CAUTION**

**Do not attempt to store more chain in chain container than that specified in the table below or serious damage to hoist may result and hazardous conditions may be created.**

Available chain containers include the standard containers designed for lifts of up to 50 ft on single-chained hoists and 25 ft on double-chained hoists. For longer lifts, the JLC927-4 container is available. For applications where a fabric bag is preferred, the JLC927-20F, JLC927-40F and the JLC927-70F are all options.

Instructions are provided with each of these chain containers and must be adhered to closely to ensure a proper installation. To install the long lift chain container or a fabric chain container, you must follow instruction sheets provided with the chain container. The following instructions are for the standard metal chain containers only.

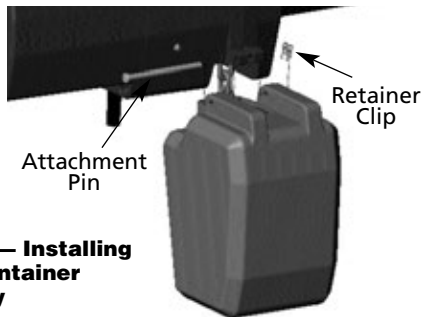

**Figure 2 — Installing Chain Container Assembly**

### Installation of Standard Chain Container (JLC927-1)

Refer to Figure 2.

1. Remove retaining clip and attachment pin and let the slack chain hang free.
2. Run load hook down to its lowest position. Place the slack end of chain in chain container. Do not remove the chain stop.
3. Place chain container flush against housing with chain stripper between top lugs. Insert long attachment pin and replace retaining clip.

## CAUTION

**Do not allow load to come in contact with the chain container. If this situation exists reset the “UP” limit switch so that the hook block stops below the chain container (See LIMIT SWITCH ADJUSTMENT, page 10).**

**Table 3 - Optional Chain Containers**

| Chain Container Model | Recommended for Use With: Hoist Capacity | Maximum Lift (ft) | Container Material                | Dimensions in Inches          |                               |                                |
|-----------------------|--|-------------------|-----------------------------------|-------------------------------|-------------------------------|--------------------------------|
|                       |  |                   |                                   | Width                         | Length                        | Depth                          |
| JLC927-1              | 1 Ton & Under<br>2 Ton                   | 20<br>10          | Molded Container                  | 6 <sup>7</sup> / <sub>8</sub> | 6 <sup>1</sup> / <sub>2</sub> | 10 <sup>1</sup> / <sub>2</sub> |
| JLC927-2              | 1 Ton & Under<br>2 Ton                   | 35<br>17          | Molded Container                  | 6 <sup>1</sup> / <sub>2</sub> | 6 <sup>1</sup> / <sub>2</sub> | 16                             |
| JLC927-3              | 1 Ton & Under<br>2 Ton                   | 50<br>25          | Molded Container                  | 6 <sup>1</sup> / <sub>2</sub> | 6 <sup>1</sup> / <sub>2</sub> | 20 <sup>1</sup> / <sub>4</sub> |
| JLC927-4              | 1 Ton & Under<br>2 Ton                   | 143<br>71         | Steel or Molded Container         | *                             | *                             | *                              |
| JLC927-20F            | 1 Ton & Under<br>2 Ton                   | 20<br>10          | Open Weave Vinyl Coated Polyester | 7 <sup>1</sup> / <sub>2</sub> | 7 <sup>1</sup> / <sub>2</sub> | 10                             |
| JLC927-40F            | 1 Ton & Under<br>2 Ton                   | 40<br>20          | Open Weave Vinyl Coated Polyester | 7 <sup>1</sup> / <sub>2</sub> | 7 <sup>1</sup> / <sub>2</sub> | 16                             |
| JLC927-70F            | 1 Ton & Under<br>2 Ton                   | 70<br>35          | Open Weave Vinyl Coated Polyester | 7 <sup>1</sup> / <sub>2</sub> | 7 <sup>1</sup> / <sub>2</sub> | 20                             |

\* Dimensions depend on length of lift. Contact Factory.

4. Feed the remainder of chain into container by operating hoist in the “UP” direction to the top limit. This will permit the chain to pile freely and prevent the chain from kinking, which may occur if the chain is placed in the container by hand.

## OPERATION

### OVERLOAD LIMITING PROTECTION

This hoist is equipped with a factory-calibrated overload limiting clutch that will permit the lifting of loads within its rated capacity, but will prevent the lifting of damaging overloads while the hoist is being operated. If the load being lifted exceeds the lifting capability of the overload clutch, the hoist motor will continue to run, causing overheating of both the clutch and hoist motor. This condition should be avoided by immediately releasing the “UP” button and reducing the load to within the rated capacity of the hoist. See GEARING, page 12, for additional instructions on this device.

## CAUTION

**The overload limiting clutch is an emergency protective device and should not be used to measure the maximum load to be lifted, or to sense the overload imposed by a constrained load. While the overload limiting clutch will protect the hoist from damaging overloads, it will not ensure that a load is within the rated capacity of the hoist.**

### SAFE OPERATION

This hoist and trolley unit is designed for safe operation within the limits of its rated capacity. Using the control station, the operator has full control in one hand – positioning the hoist with the “LEFT” and “RIGHT” trolley buttons and lifting or lowering a load with the “UP” and “DOWN” hoist buttons. To ensure safe operation, the following guidelines must be observed.

1. Above all, always use common sense when operating the hoist and trolley. Refer to all of the safety guidelines listed in the General Safety Information section of this manual and to ASME B30.16 Safety Code for Overhead Hoists.

2. Use the “LEFT” and “RIGHT” buttons to position the unit over the load. The load should be directly under the hoist before attaching the load hook. The hoist and trolley are designed for vertical lifting only. Never lift a load that is off center with the hoist.
3. Before raising a load, always check to see that it is held securely in the saddle of the hook. Never allow a load to be applied at the tip of the hook. Raise the load only until the load chain is taut and then double check the rigging before continuing to raise the load.
4. Stand clear of the load at all times. Before moving the load along the runway beam, ensure that all personnel are clear of the runway path and are aware of your intentions.
5. With the load suspended, push the “LEFT” or “RIGHT” button to move the load in the desired direction. Avoid letting the load swing excessively while moving the trolley. Always allow the trolley to coast to a stop before reversing its direction. Sudden reversal of the trolley motor causes it to overheat and the load will begin to sway.
6. The operator should have a clear view of the load anytime it is moving and should be sure that the load does not contact any obstructions. Never leave a suspended load unattended.
7. Do not run the trolley into beam end stops or other trolleys on the beam.
8. Never use the hoist and trolley to transport people or to move loads over people.
9. Do not overload the hoist.
10. Do not make side pulls with the hoist.
11. Do not “sling” the load hook and chain around the load. Use an approved sling.
12. **Be sure there are no twists in the load chain** as it travels into the hoist housing. This condition should be constantly checked on double-chained hoists because it is possible for the load block to be “capsized” or turned over one or more times.
13. Do not operate if direction of hook travel is not the same as indicated on button being pushed.
14. Do not operate unless hook travel limit devices function. Test without load each shift.
15. Do not operate if chain is not seated properly in sprockets or sheave grooves.
16. Do not operate a damaged or malfunctioning hoist or trolley.

## ⚠ WARNING

**Do not use hoist to lift, support or otherwise transport people.**

# MAINTENANCE

## INSPECTIONS

A planned inspection routine should be established for this hoist based upon frequency of use, severity of use, and environmental conditions (Reference ASME Standard B30.16). Some inspections should be made frequently (daily to monthly) and others periodically (monthly to yearly). It is strongly recommended that an Inspection and Maintenance Check List and an Inspector’s Report, similar to those shown in Figures

13A and 13B, be used and filed for reference. All inspections should be performed or overseen by a designated inspector. Special inspections should be made following any significant repairs or any operating occurrence leading one to suspect that the hoist’s capability may have been impaired.

## LOWERING WITHOUT POWER

If the power fails with a load suspended, the hoist will automatically stop. In an emergency the load can be lowered without power as follows:

1. DISCONNECT HOIST FROM POWER SUPPLY AND REMOVE ELECTRICAL COVER.

## ⚠ WARNING

**Do not allow screw driver blades to touch rotating friction disc “C”.**

## ⚠ CAUTION

**Do not allow the load to descend rapidly. This causes the motor to race and serious damage may result.**

2. Refer to Figure 6. Open disc brake manually by using two screwdriver blades, one on each side of the brake at a point close to the brake spring posts. Apply pressure to the underside of the armature plate (points “X”) to close the solenoid and release the brake.
3. Use several quick releases instead of holding brake open continuously. Do not exceed normal lowering speed.

## HOOKS

Refer to Figure 3.

1. Inspect the load hook once daily for cracking, extreme wear or spreading. Replace the hook if it is showing any of these signs. If the throat opening is spread wider than the maximum permissible 15% increase listed here, the hook has been overstressed and must be replaced. Any hook that is bent or twisted more than 10 degrees from the plane of an unbent hook must also be replaced. Material wear in the saddle of the hook should not exceed 10% of the original thickness.

**Figure 3 — Hook Inspection**

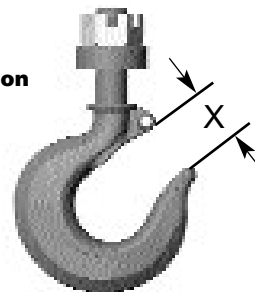

| Hoist Capacity | “T” Dimension     | “X” Dimension* |
|----------------|-------------------|----------------|
|                | Minimum Thickness | Bottom Hook    |

|               |                                  |                                   |
|---------------|----------------------------------|-----------------------------------|
| 1 Ton & Under | 31/32"                           | 1 <sup>7</sup> / <sub>32</sub> "  |
| 2 Ton         | 1 <sup>5</sup> / <sub>32</sub> " | 1 <sup>11</sup> / <sub>32</sub> " |

(\* ) Maximum permissible throat opening of hook.



- Inspect to see that the hook latch performs the function of closing off the hook throat opening in a secure manner when a load is attached. Also, inspect the hook's threaded connections for stripping or other damage. The retaining pin should be intact.
- Load hooks should be inspected for cracks by the magnetic particle, dye penetrant or other suitable crack testing inspection method. This should be done at least once a year.

## CHAIN

Chain is to be kept clean and lubricated (See LUBRICATION, page 11). Visually check chain every time hoist is used. Hoist must not be operated when chain is twisted or kinked. An important part of hoist maintenance is chain inspection. Check individual links and check for chain elongation.

- Check the chain for overall wear or stretch by selecting an unworn, unstretched length of chain (at the slack end for example). Let the chain hang vertically with a light load (about 20 pounds) on the chain to pull it taut. Use a large caliper to measure the outside length of a convenient number of links (about 12 inches). Measure the same number of links in a used section of chain and calculate the percentage increase in length of the worn chain.

### **CAUTION**

**The chain used on this hoist has very carefully controlled dimensions and has been heat treated. Do not attempt to substitute other manufacturer's chain.**

- If the length of the worn chain is more than 1½% longer than the unused chain (0.015" per inch of chain measured), then the chain should be replaced. If the chain is worn less than 1½%, check it at several more places along its length. If any section is worn more than 1½%, the chain should be replaced.

## CHAIN REPLACEMENT WITH CHAIN IN HOIST

Refer to Figure 4 & 5.

- Run hook up to its top limit.
- DISCONNECT HOIST FROM POWER SUPPLY and remove the electrical cover.

### **WARNING**

**Always disconnect power source before working on or near a hoist or its connected load. If the power disconnect point is out of sight, lock it in the open position and tag to prevent unexpected application of power.**

- Using a screwdriver, pry the spring guide plate out of the slots in the limit switch nuts (See Figure 4). Turn the gold nut back to about the center of the threaded screw. Do not disconnect the wires from the limit switches.
- Remove the load block assembly from the old chain. On double-chained hoists detach the chain from the chain support and pull it through the load block assembly.
- Make a "C" shaped chain link by grinding through the end link on the load end of the old chain.

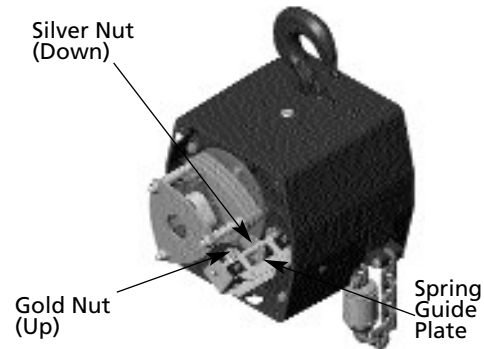

**Figure 4 — Limit Switch Adjustment for Chain Replacement**

- Using the "C" link, attach the new chain to the load end of the old chain. Be sure that the welds of the upstanding links of the new chain will face outward from the load sheave. The end links must be oriented for attachment to the dead-end screw and the chain support (double-chained only) without any twist in the chain.



**Figure 5 — Chain Replacement Diagram**

- With the electrical cover off, connect the hoist to the power supply. Be sure that the green ground wire is properly grounded, (See ELECTRICAL CONNECTIONS, page 6).
- Carefully jog the "UP" button and run the joined pieces of chain into the hoist until about 15" of the new chain comes out the other side.
- DISCONNECT HOIST FROM POWER SUPPLY.
- Remove the "C" link and the old chain. Remove the chain stop from the old chain by prying off its retaining ring with a flathead screwdriver. If attached, remove the old chain from the side of the hoist by removing the dead-end screw and washers (note placement of washers).
- Attach the chain stop to the slack end of the new chain by capturing the 12th link with the two stop halves positioned with their tapered ends pointing towards the hoist. Slide the sleeve over the halves and attach the retaining ring. If you are not using a chain container, attach the slack end of the new chain to the side of the hoist using the dead-end screw and washers. With factory supplied hardware there should be six washers between the hoist and chain link and two washers between the chain link and screw head. DO NOT allow twists in the chain.
- Adjust the lower limit switch (See ADJUSTING LOWER LIMIT, page 10).

13. Attach the bottom block on single-chained hoists using a new load block pin (See Figure 28). On double-chained hoists, feed the chain through the load block (welds of the upstanding links will be in towards the sheave) and fasten the end of the chain to the chain support using a new chain support pin (See Figure 28). **Be sure there are no twists in the chain.**
14. Adjust the upper limit switch (See ADJUSTING UPPER LIMIT, page 10).

### CHAIN REPLACEMENT WITH NO CHAIN IN HOIST

Refer to Figures 5 and 6.

1. DISCONNECT HOIST FROM POWER SUPPLY. Remove the hoist and trolley from the beam (follow reverse of INSTALLATION, page 5).
2. Remove the trolley from the suspension lug.
3. Remove the electrical cover, panel plate and electric motor brake.
4. Detach the chain stripper from the bottom of the hoist.
5. Insert the new chain between the load sheave and the chain guide. Feed the chain into the hoist by manually turning the brake hub. Allow about 15" of chain below the hoist on the slack end (See Figure 6). Be sure the welds of the upstanding links are out away from the load sheave and the proper orientation is observed for attachment of the slack end. Also be sure the load hook assembly (if already attached to the chain) is toward the center of the hoist or to your right looking from the transmission end.

## CAUTION

**There are wires running through the hoist. Carefully ease the hoist sections apart. Do not jerk them apart.**

4. Reinstall the chain stripper (with the chain anchor on double-chained hoists) observing proper chain alignment and avoiding any twist in the chain
5. Replace the electric motor brake, panel plate and electrical cover. Be careful not to pinch any of the wiring.
6. Reattach the lug and trolley
7. Follow steps 11 through 14 in the previous section, CHAIN REPLACEMENT WITH CHAIN IN HOIST, to complete the chain replacement procedure. Reinstall the unit as described in INSTALLATION, page 5.

### LIMIT SWITCH ADJUSTMENT

**IMPORTANT:** Before placing hoist in operation, check the limit switch adjustment. Limit switches are provided to protect the hoist against damage resulting from overtravel or to allow setting the hook travel within the factory-set limits of travel. The standard limit switch is designed for lifts of 50 ft or less on single-chained hoists and 25 ft or less on the 2 ton, double-chained models. The long lift limit switch allows for the maximum amount of lift, which is 134 ft on 1/2 ton and under models, 143 ft on the 1 ton models, and 71 ft on the 2 ton models.

The upper and lower limit switch adjusting nuts are color-coded gold and silver respectively. Each limit nut has 10 slots for fine adjustment, and the increment of adjustment is such that one slot is equivalent to approximately one link of chain travel with the standard limit switch (about 3 links with the long lift limit switch). Movement of the limit switch nuts toward or away from each other increases or decreases the hook travel respectively.

### ADJUSTING UPPER LIMIT (GOLD NUT)

Refer to Figure 4.

1. Suspend the hoist. For single chain models raise the load block until there is a minimum clearance of 2" from the hoist housing and the top of the block. Double chain models require a minimum clearance of 1" from the chain support to the top of the load block.
2. DISCONNECT HOIST FROM POWER SUPPLY and remove the electrical cover.
3. With a screwdriver, pry the spring guide plate out of the slots in the limit switch nuts.
4. Turn the slotted gold nut toward its limit switch until the switch "clicks" then turn two slots farther. Release the spring guide plate and be sure it slips back into the slots in both limit switch nuts. Do not disturb the silver slotted nut if it has been set previously.

### ADJUSTING LOWER LIMIT (SILVER NUT)

Refer to Figure 4.

1. Suspend the hoist. Carefully lower the load block to a point where the slack-end loop of the chain hangs down 6" or more from the hoist housing (or the limit desired in any particular application allowing the minimum 6"). There should be a minimum clearance of 1½" between the chain stop and the bottom of the hoist.
2. DISCONNECT HOIST FROM POWER SUPPLY and remove the electrical cover.
3. With a screwdriver, pry the spring guide plate out of the slots in the limit switch nuts.
4. Turn the slotted silver nut toward its limit switch until the switch "clicks," then turn two slots farther. Release the spring guide plate and be sure it slips back in the slots in both limit switch nuts. Do not disturb the gold slotted nut if it has been set previously.

## CHECK BOTH UPPER AND LOWER LIMITS

1. Connect the hoist to the power supply. Be sure the green ground wire is properly grounded (See ELECTRICAL CONNECTIONS, page 6).
2. Check load hook direction (See ELECTRICAL CONNECTIONS 4, page 6).
3. Carefully raise load block to upper limit and observe if it stops automatically at desired level. Do not allow load block to run into hoist housing — this will damage the hoist. Maintain a minimum clearance of 2" from the hoist housing and the top of the load block on single-chained models and 1" from the chain support to the top of the load block on double-chained models.
4. Carefully lower load block to lower limit and observe if it stops automatically at the desired level. Do not allow slack chain, if attached to the dead-end screw, to become taut against hoist housing. This will damage the hoist. There should be a minimum clearance of 1½" between the chain stop and the bottom of the hoist.
5. If upper and lower limits operate satisfactorily, hoist is ready for use. If they are not as desired, repeat adjustment.

## CAUTION

If the wires running to the limit switches are ever disconnected for any purpose, be sure to replace wires in accordance with the correct wiring diagram (See Figures 12A - 12F).

## HOIST BRAKE

Properly adjusted, this brake will release promptly when energized. It is capable of both smoothly stopping and securely holding the rated capacity of the hoist. If the hoist develops either undesirable over-travel after the pushbutton is released (this condition is most noticeable in the lowering direction) or hesitates to lift the load promptly when the pushbutton is depressed (this condition is most noticeable in the hoisting direction), the brake should be adjusted.

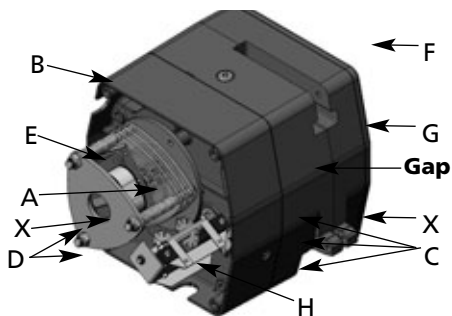

Figure 6 — Brake Assembly

## WARNING

Always disconnect power source before working on or near a hoist or its connected load. If the power disconnect point is out of sight, lock it in the open position and tag to prevent unexpected application of power.

## BRAKE ADJUSTMENT

Refer to Figure 6.

1. DISCONNECT HOIST FROM POWER SUPPLY and remove the electrical cover.
2. With reference to Figure 6, the gap between the brake armature "A" and the field "B" should be checked. The correct gap is 0.015". Adjustment should not be necessary until gap reaches 0.040".

## CAUTION

Be sure the bottom of the armature does not bear against the splined adapter "H". As adjustments are made, the built-in clearance will be reduced. When this clearance is gone REPLACE BRAKE DISCS. Minimum allowable disc thickness is .162".

3. Adjust gap by adjusting the 3 locknuts "F" and checking with a feeler gauge to be sure gap is the same on both ends of the solenoid.
4. Adjustment is now complete and the brake properly set. Replace the electrical cover, reconnect the power supply, and check hoist brake action.

## LUBRICATION

Refer to Figure 14.

Proper lubrication is necessary for a long and relatively trouble-free hoist operation. Refer to the following and Figure 14 for lubrication points, type of lubricant, and frequency of lubrication.

### Load Chain

Clean the load chain with acid-free solvent and coat with SAE 90 gear oil. Wipe excess oil to prevent dripping. Never apply grease to the chain.

### Gearing

The gear case of this hoist is filled at assembly with approximately 1½ pints of SAE 90 EP gear oil. Check oil level by removing the oil level check plug from the side of the hoist. With the hoist hanging level, gear oil should be even with the hole. Change oil periodically depending on the severity of the application and the environmental conditions (at least every 200 hours of run time).

### Bearings

All bearings except hook and idler sheave bearings are lubricated at the factory and should not require additional lubrication. Noisy or worn bearings should be replaced.

### Limit Switch Shaft

Remove any dirt accumulation and spray with a general purpose lubricant.

### Hook Bearing

Apply a few drops of SAE 30 gear oil around the edge of the bearing.

### Idler Sheave Bearing (Bushing) - 2 Ton Models

Disassemble load block and apply a light coat of NLGI #2 grease, or equivalent, inside of bearing.

## HOIST REPAIRS

1. For major repairs or when the hoist is to be sectioned in the suspension area, it will be necessary to move the hoist to a workbench or table.
2. For repairs which can be done by removing the electrical cover only, the hoist need not be moved. Lowering the hoist to a convenient working level is desirable.

**NOTE:** If you do not have an experienced mechanic/electrician to do your repair work, we recommend that you send your hoist to an approved service center for repairs. Use authorized repair parts only. The following repair instructions will help you in understanding repair procedures, when related to the Repair Parts List starting on page 26. For clarity these are broken down into areas.

## ⚠ WARNING

**Remove load and disconnect hoist from power supply before starting to do any repairs or to take any sections apart.**

## ELECTRICAL PARTS AND BRAKE

1. Refer to the correct wiring diagram for your hoist. Standard wiring for units without extra electrical options are shown in Figures 12A - 12F. In the case of standard units with a 1-speed hoist and 1-speed trolley, all the controls are located inside the hoist cover. Any hoist/trolley combinations with a two-speed motor require a control box on the trolley to house the trolley controls.

The contactors, terminal blocks and end clamps are mounted on DIN rail (See Figure 8). Remove the blocks and clamps by prying their "feet" with a small screwdriver. **DO NOT SLIDE THE END CLAMPS.** Reversing contactors can be slid off the rail, but they are attached to the rail by snapping. Where the contactor fits the rail, one side has springs or pads that apply pressure against one edge of the rail. By pressing against that side at the base of the contactor, you can snap the part on or pull it off using a rotating action (the contactor pivots about the other edge of the rail). Some components, such as a two-speed relay, may attach using a spring loaded retaining clip at their base.

When replacing contactors, orient them so that the numbering on the screw clamps corresponds with the wiring diagram. Reversing contactors consist of an "UP" contactor and a "DOWN" contactor. Note that single-phase contactors have a small jumper joining the 3 and 5 screw clamps on the "DOWN" contactor (See Figure 12A). Always be sure that all the clamps are tightened. Loose clamps will limit the power flow to the hoist.

**Figure 7 -  
Electrical  
Panel  
Removed**

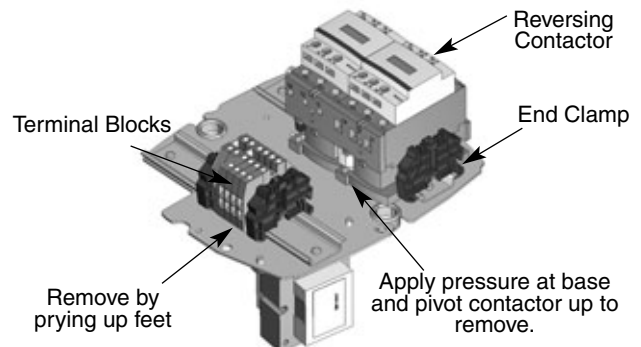
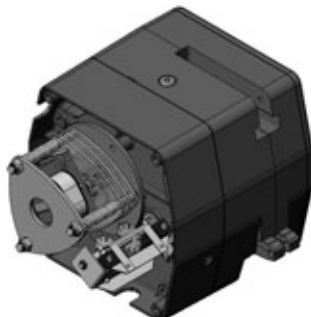

**Figure 8 - Hoist Electrical Panel**

2. Remove the electrical panel by removing the stand-off screws (See Figures 19 & 20). The limit switch and brake are now accessible as shown in Figure 7.
3. Remove the transformer bolted to the back of the panel plate if it requires replacement.
4. Refer to Figure 18 to disassemble the brake. See BRAKE ADJUSTMENT on page 11 to properly set the brake.
5. Refer to Figures 25 and 26 to disassemble the limit switch. See LIMIT SWITCH ADJUSTMENT on page 10 to properly set the upper and lower limits of travel.
6. Refer to Figures 22 - 24 for repairs on the pushbutton station. Also refer to the wiring diagram inside the electrical cover or Figures 12A - 12F, pages 18-21 for wiring instructions.

## HOIST MOTOR

Refer to Figures 15 - 17.

The hoist motor is located on the opposite end to that of the electrical parts, but the two are tied together with electrical leads running through the housing.

1. If it is necessary to replace or repair the motor, **DISCONNECT THE HOIST FROM THE POWER SUPPLY** and remove the electrical cover.
2. Loosen the screw clamps on the terminal blocks and reversing contactor to disconnect the motor leads (See Figures 19 and 20).
3. Remove the four motor mounting bolts attaching the motor to the housing. It will come loose at the motor coupling.
4. Inspect the motor coupling, motor shaft and all the bearings. Replace as necessary.
5. Install new or repaired motor according to the wiring diagram located inside the electrical cover or Figures 12A - 12F.

## GEARING

Refer to Figures 15 and 27.

**DISCONNECT HOIST FROM POWER SUPPLY.** Remove the hoist and trolley from the beam (follow reverse of INSTALLATION, page 5). Disassemble the trolley from the hoist.

1. Remove electrical cover.
2. Remove electrical panel.
3. Remove brake assembly and limit switch assembly.
4. Drain oil from transmission.

## **CAUTION**

**Do not disassemble or readjust the clutch, or replace it with a clutch assembly from another hoist. Doing so will void the warranty and may create an unsafe condition. If replacement is needed due to wear or loss of adjustment, always use a new clutch assembly.**

5. Remove four screws attaching gear box cover to gear housing and remove gear box cover. Limit switch drive shaft will come along with the cover.



**Figure 9 - Assembled Gearing**

6. Inspect gears for broken or severely worn teeth and inspect all bearings. Replace as necessary. The overload slip clutch is factory calibrated and must not be disassembled or readjusted.
7. Reassemble in reverse order of disassembly making sure gasket is in place and in good condition. Coat gasket with Permatex® or other gasket cement. Extreme care should be taken to avoid damage to oil seals.
8. Check all wire terminals to be sure they are properly seated and in accordance with wiring diagram. Check brake adjustment and limit switch settings. Follow INSTALLATION, page 5 to reinstall the unit.

## **SUSPENSION**

Refer to Figures 15, 28 and 29.

The sheave housing and the gear housing must be separated to remove the lug suspension, chain guides and plates, and chain support (2-ton models); and to inspect the load sheave.

1. DISCONNECT HOIST FROM POWER SUPPLY.  
Disassemble the trolley from the suspension lug.
2. Lay the hoist on its side and remove the four screws holding the sheave and gear housings together. Refer to CHAIN REPLACEMENT WITH NO CHAIN IN HOIST for more information on working on this section of the hoist. Carefully pull the motor and sheave housing assembly from the hoist. Turn the two hoist sections at right angles. Be careful not to damage any motor leads, which run from the motor to the other side of the hoist.
3. The lug assembly is easily removed once the housings are pulled apart. It should be inspected for any deficiencies in the lug, lug nut or retaining pin. The load sheave, chain guides and plates, chain support (2-ton models) and bearing should be inspected at this point. Replacement of the load sheave requires disassembly of the gearbox (see GEARING, page 12).



**Figure 10A - Suspension for 1-Ton**



**Figure 10B - Suspension for 2-Ton**

4. Replace parts as necessary, including any associated hardware. Refer to CHAIN REPLACEMENT WITH NO CHAIN IN HOIST, page 10 for reassembly. When reassembled, check that the travel limit switches are set correctly (see LIMIT SWITCH ADJUSTMENT, page 10).

## **TROLLEY MAINTENANCE**

No routine maintenance of the trolley is required other than wheel gear lubrication. The trolley should be inspected for damage, loose parts, and excessive wheel wear at the same time as the hoist inspections.

## **CAUTION**

**Any deficiencies are to be corrected before the hoist and trolley is returned to service. Also, the external conditions may show the need for disassembly to permit a more detailed inspection, which, in turn, may require the use of nondestructive type testing.**

## **TROLLEY LUBRICATION**

### **TROLLEY WHEEL GEARS**

Lubricate the trolley wheel gears at the periodic inspections with an NLGI #2 or heavier grease.

### **TROLLEY TRANSMISSION**

Periodic lubrication is not necessary. If the gearbox is opened for repair, repack with an NLGI #1 grease.

### **TROLLEY WHEEL BEARINGS**

Trolley wheel bearings are prelubricated and sealed. Bearings must be replaced if problems are indicated.

## **OPTIONAL TROLLEY BRAKE**

Refer to Figure 31. Units that are supplied with an optional trolley brake utilize a trolley transmission that allows the brake assembly to be mounted opposite the trolley motor. The brake must be maintained similarly to the hoist brake (see HOIST BRAKE, page 11). The gap between the brake armature and the field is factory set to 0.015". Do not allow the gap to exceed 0.040".

## TROLLEY INSPECTION

At regularly scheduled hoist inspections, ensure that the following conditions, as well as any other unsafe conditions, do not exist.

1. Loose fasteners, such as the load pin and wheel nuts.
2. Damaged electrical cables or wires.
3. Loose or corroded terminals and other electrical connections.
4. Excessive wear of wheel tread and flange.
5. Excessive wear of wheel gears and output pinion.
6. Cracks, excessive wear or other damage that may decrease the strength of the suspension lug.

## TROLLEY REPAIRS

If you do not have an experienced mechanic/electrician to do your repair work, we recommend that you send your hoist to an approved service center for repairs. Use authorized repair parts only. The following are instructions for minor repairs that may not require a service center.

### ELECTRICAL PARTS

The trolley motor controls include a reversing contactor, and, in the case of 2-speed motors, a speed control relay. These components are located under the hoist electrical cover or in a separate trolley control box (See Figures 19 and 21). See **ELECTRICAL PARTS AND BRAKE**, page 12, for more information on replacing electrical parts.

## TROLLEY MOTOR

1. If it is necessary to replace or repair the motor, **DISCONNECT THE UNIT FROM THE POWER SUPPLY**, and remove the splice plate on the trolley junction box.
2. Disconnect the motor leads from the tie cable. Be sure that all the wires retain their markings.
3. Remove the four motor mounting bolts and pull the motor away from the trolley transmission.
4. Inspect the motor shaft and all the bearings, replace as necessary.
5. Install the new or repaired motor according to the wiring diagram intended for your unit (See Figures 12A - 12F for standard diagrams).

## **WARNING**

**Remove load and disconnect hoist from power supply before starting to do any repairs or to take any sections apart.**

## TROLLEY WHEELS

Worn wheels should be replaced with new assemblies. Remove the locknut from the wheel shaft and remove the assembly. Replace with a new assembly, which includes a new locknut. Be sure to replace the washers and tighten nuts to **100 ft-lbs**.

## POWER CORD PRECAUTIONS WITH 1-PHASE HOISTS

Electric hoists require a sufficient power supply. It is especially important with single-phase voltage to ensure that the conductors running to the hoist from the power source are adequate in size to handle the power requirements of the hoist. Inadequate **power cables** and **branch circuits** will cause low voltage, high amperage, damage to the hoist, and potential fire hazards. Such problems can be minimized by using 230V power on 115/230V hoists. The following are recommendations for the conductor gage size depending on the length, horsepower, and voltage.

**Table 4 - Recommended Conductor Sizes for 1-Phase Hoists**

| HP  | Voltage<br>(1-Phase) | Maximum Length of Power Cord in Feet |        |        |       |
|-----|----------------------|--------------------------------------|--------|--------|-------|
|     |                      | 14 AWG                               | 12 AWG | 10 AWG | 8 AWG |
| 1/4 | 115V                 | 75                                   | 120    | 190    | 300   |
|     | 230V                 | 350                                  | 560    | 900    |       |
| 1/2 | 115V                 | 40                                   | 60     | 100    | 150   |
|     | 230V                 | 200                                  | 330    | 520    | 810   |
| 1   | 115V                 | 0                                    | 30     | 50     | 75    |
|     | 230V                 | 120                                  | 190    | 310    | 490   |



## Spacer Washer Location

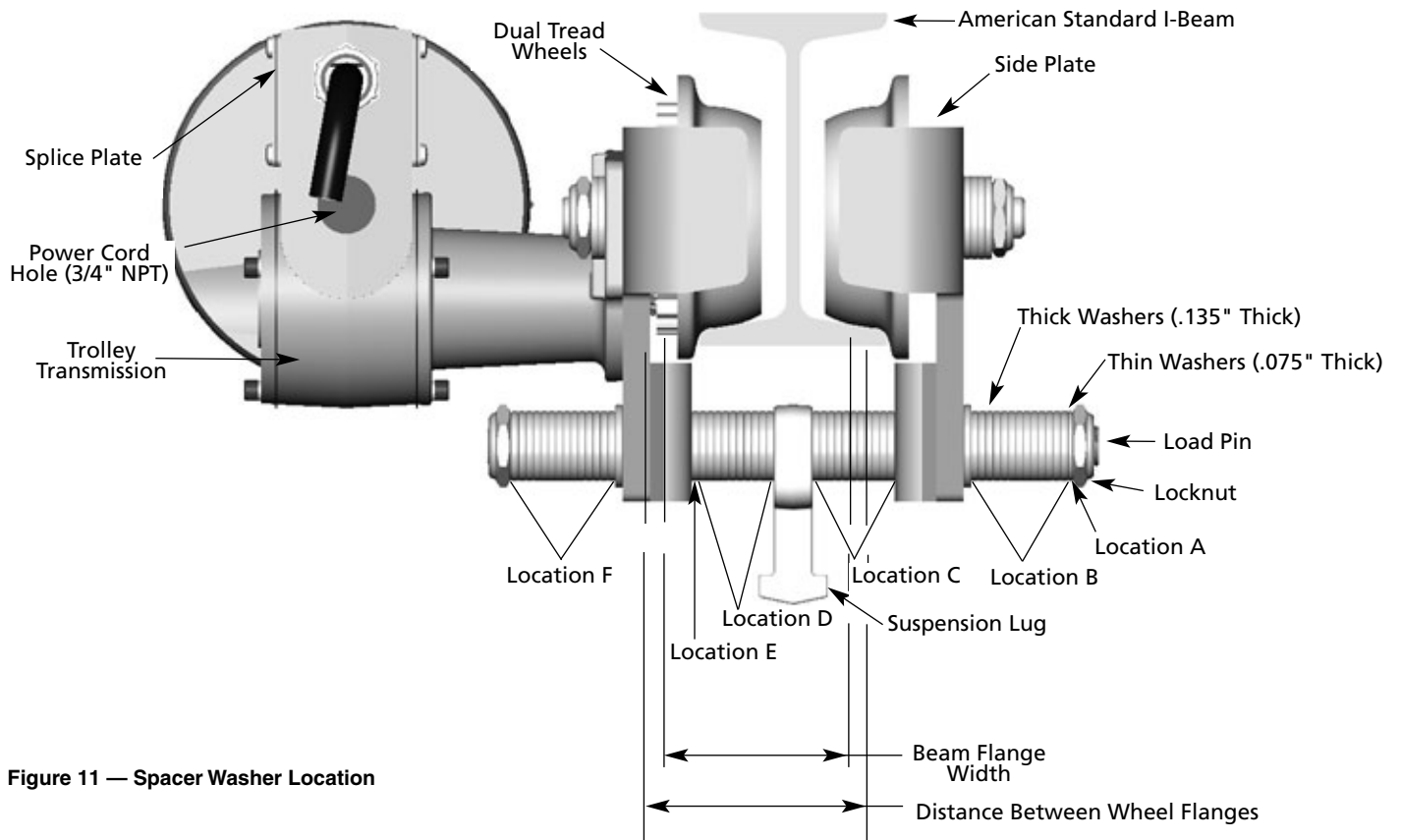

Figure 11 — Spacer Washer Location

Table 5 - American Standard I-Beam (Tapered Flange)

| STANDARD BEAM Size & Weight | Flange Width | Location A H4210 (Thin) | Location B H4209 (Thick) | Location C H4209 (Thick) | Location D H4209 (Thick) | Location E H4210 (Thin) | Location F H4209 (Thick) |
|-----------------------------|--------------|-------------------------|--------------------------|--------------------------|--------------------------|-------------------------|--------------------------|
| 6" x 12.5#                  | 3.332        | 1                       | 13                       | 11                       | 11                       | 0                       | 14                       |
| 6" x 17.3#                  | 3.565        | 0                       | 13                       | 12                       | 11                       | 1                       | 13                       |
| 7" x 15.3#                  | 3.662        | 0                       | 12                       | 12                       | 12                       | 1                       | 13                       |
| 7" x 20.0#                  | 3.860        | 1                       | 11                       | 13                       | 13                       | 0                       | 12                       |
| 8" x 18.4#                  | 4.001        | 1                       | 11                       | 14                       | 13                       | 0                       | 11                       |
| 8" x 23.0#                  | 4.171        | 1                       | 10                       | 14                       | 14                       | 0                       | 11                       |
| 10" x 25.4#                 | 4.661        | 0                       | 9                        | 16                       | 15                       | 1                       | 9                        |
| 10" x 35.0#                 | 4.944        | 1                       | 7                        | 17                       | 17                       | 0                       | 8                        |
| 12" x 31.8#                 | 5.000        | 1                       | 7                        | 17                       | 17                       | 0                       | 8                        |
| 12" x 35.0#                 | 5.078        | 1                       | 7                        | 18                       | 17                       | 0                       | 7                        |
| 12" x 40.8#                 | 5.252        | 1                       | 6                        | 18                       | 18                       | 0                       | 7                        |
| 12" x 50.0#                 | 5.477        | 0                       | 6                        | 19                       | 18                       | 1                       | 6                        |
| 15" x 42.9#                 | 5.501        | 1                       | 5                        | 19                       | 19                       | 0                       | 6                        |
| 15" x 50.0#                 | 5.640        | 1                       | 5                        | 20                       | 19                       | 0                       | 5                        |
| 18" x 54.7#                 | 6.001        | 0                       | 4                        | 21                       | 20                       | 1                       | 4                        |
| 18" x 70.0#                 | 6.251        | 0                       | 3                        | 22                       | 21                       | 1                       | 3                        |
| 20" x 66.0#                 | 6.255        | 0                       | 3                        | 22                       | 21                       | 1                       | 3                        |
| 24" x 80.0#                 | 7.000        | 1                       | 0                        | 25                       | 24                       | 0                       | 0                        |

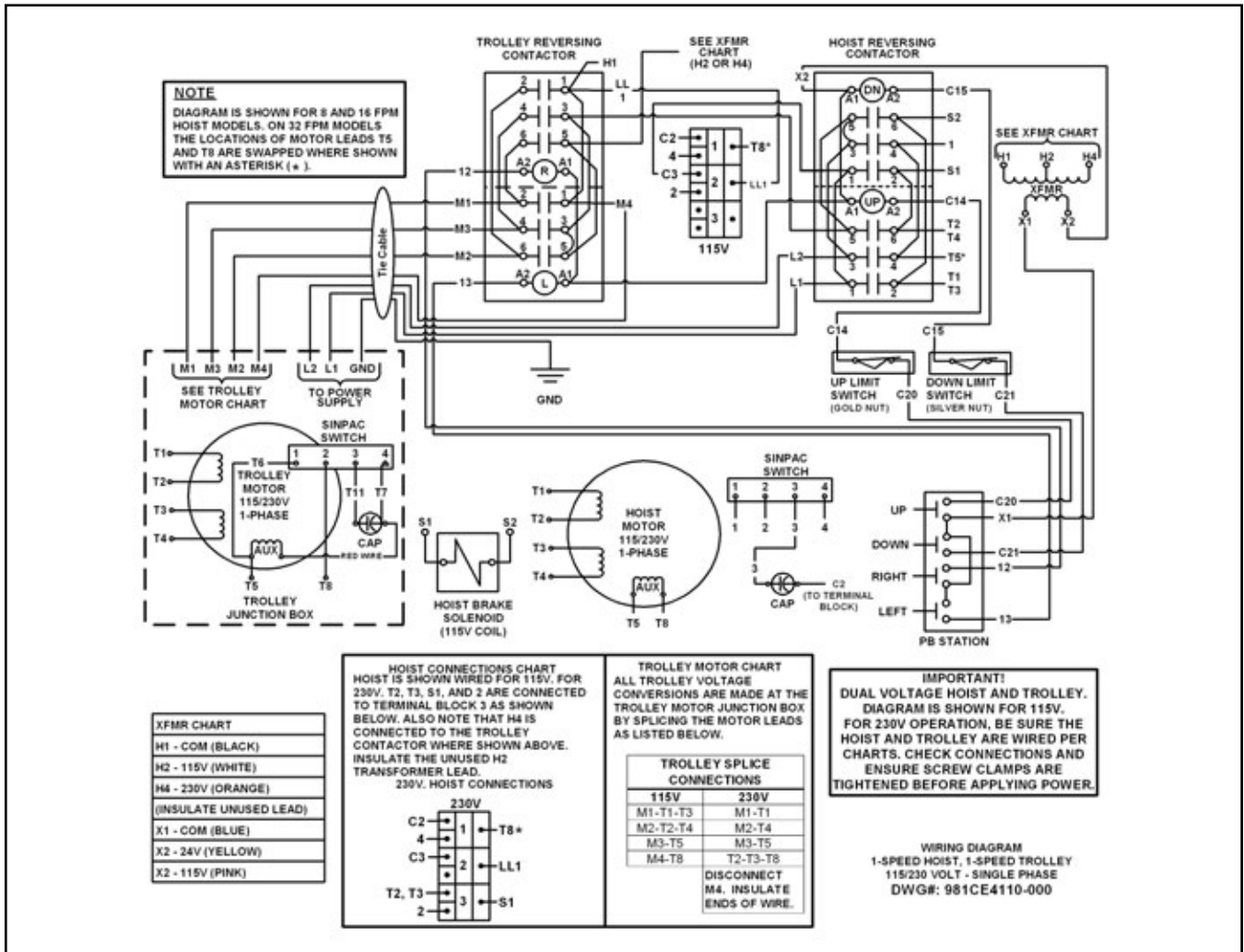

**Table 6 — Wide Flange Beam (Flat Flange)**

| WIDE FLANGE<br>BEAM<br>Size & Weight | Flange<br>Width | Location A<br>H4210<br>(Thin) | Location B<br>H4209<br>(Thick) | Location C<br>H4209<br>(Thick) | Location D<br>H4209<br>(Thick) | Location E<br>H4210<br>(Thin) | Location F<br>H4209<br>(Thick) |
|--------------------------------------|-----------------|-------------------------------|--------------------------------|--------------------------------|--------------------------------|-------------------------------|--------------------------------|
| 5" x 16.0#, 14" x 22.0#              | 5.000           | 0                             | 7                              | 17                             | 17                             | 1                             | 8                              |
| 5" x 19.0#                           | 5.030           | 1                             | 7                              | 18                             | 17                             | 0                             | 7                              |
| 6" x 9.0#, 8" x 10.0#                | 3.940           | 0                             | 11                             | 13                             | 13                             | 1                             | 12                             |
| 6" x 12.0#, 8" x 13.0#               | 4.000           | 1                             | 11                             | 14                             | 13                             | 0                             | 11                             |
| 6" x 15.0#                           | 5.990           | 1                             | 3                              | 21                             | 21                             | 0                             | 4                              |
| 6" x 16.0#, 12" x 22.0#              | 4.030           | 0                             | 11                             | 14                             | 13                             | 1                             | 11                             |
| 6" x 20.0#                           | 6.020           | 1                             | 3                              | 21                             | 21                             | 0                             | 4                              |
| 6" x 25.0#                           | 6.080           | 0                             | 3                              | 21                             | 21                             | 1                             | 4                              |
| 8" x 15.0#                           | 4.015           | 0                             | 11                             | 14                             | 13                             | 1                             | 11                             |
| 8" x 18.0#                           | 5.250           | 0                             | 6                              | 18                             | 18                             | 1                             | 7                              |
| 8" x 21.0#                           | 5.270           | 0                             | 6                              | 18                             | 18                             | 1                             | 7                              |
| 8" x 24.0#                           | 6.495           | 1                             | 1                              | 23                             | 23                             | 0                             | 2                              |
| 8" x 28.0#                           | 6.535           | 1                             | 1                              | 23                             | 23                             | 0                             | 2                              |
| 10" x 12.0#                          | 3.960           | 1                             | 11                             | 14                             | 13                             | 0                             | 11                             |
| 10" x 15.0#                          | 4.000           | 1                             | 11                             | 14                             | 13                             | 0                             | 11                             |
| 10" x 17.0#                          | 4.010           | 0                             | 11                             | 14                             | 13                             | 1                             | 11                             |
| 10" x 19.0#                          | 4.020           | 0                             | 11                             | 14                             | 13                             | 1                             | 11                             |
| 10" x 22.0#                          | 5.750           | 1                             | 4                              | 20                             | 20                             | 0                             | 5                              |
| 10" x 26.0#                          | 5.770           | 0                             | 4                              | 20                             | 20                             | 1                             | 5                              |
| 10" x 30.0#                          | 5.810           | 0                             | 4                              | 20                             | 20                             | 1                             | 5                              |
| 12" x 14.0#                          | 3.970           | 1                             | 11                             | 14                             | 13                             | 0                             | 11                             |
| 12" x 16.0#                          | 3.990           | 1                             | 11                             | 14                             | 13                             | 0                             | 11                             |
| 12" x 19.0#                          | 4.005           | 1                             | 11                             | 14                             | 13                             | 0                             | 11                             |
| 12" x 26.0#                          | 6.490           | 0                             | 2                              | 23                             | 22                             | 1                             | 2                              |
| 12" x 30.0#                          | 6.520           | 1                             | 1                              | 23                             | 23                             | 0                             | 2                              |
| 12" x 35.0#                          | 6.560           | 1                             | 1                              | 23                             | 23                             | 0                             | 2                              |
| 14" x 26.0#                          | 5.025           | 1                             | 7                              | 18                             | 17                             | 0                             | 7                              |
| 14" x 30.0#                          | 6.730           | 0                             | 1                              | 24                             | 23                             | 1                             | 1                              |
| 14" x 34.0#                          | 6.745           | 0                             | 1                              | 24                             | 23                             | 1                             | 1                              |
| 14" x 38.0#                          | 6.770           | 1                             | 0                              | 24                             | 24                             | 0                             | 1                              |
| 16" x 26.0#                          | 5.500           | 0                             | 5                              | 19                             | 19                             | 1                             | 6                              |
| 16" x 31.0#                          | 5.525           | 0                             | 5                              | 19                             | 19                             | 1                             | 6                              |
| 16" x 36.0#                          | 6.985           | 0                             | 0                              | 25                             | 24                             | 1                             | 0                              |
| 16" x 40.0#                          | 6.995           | 0                             | 0                              | 25                             | 24                             | 1                             | 0                              |
| 18" x 35.0#                          | 6.000           | 1                             | 3                              | 21                             | 21                             | 0                             | 4                              |
| 18" x 40.0#                          | 6.015           | 1                             | 3                              | 21                             | 21                             | 0                             | 4                              |
| 18" x 46.0#                          | 6.060           | 0                             | 3                              | 21                             | 21                             | 1                             | 4                              |
| 21" x 44.0#                          | 6.500           | 1                             | 1                              | 23                             | 23                             | 0                             | 2                              |
| 21" x 50.0#                          | 6.530           | 1                             | 1                              | 23                             | 23                             | 0                             | 2                              |
| 21" x 57.0#                          | 6.555           | 1                             | 1                              | 23                             | 23                             | 0                             | 2                              |
| 24" x 55.0#                          | 7.005           | 0                             | 0                              | 25                             | 24                             | 1                             | 0                              |

## WIRING DIAGRAMS

The following are standard wiring diagrams. Units that have special electrical features will have different diagrams. Specific diagrams are included with each hoist. If necessary, note the model and serial number stamped into the sheave housing of the hoist and consult the factory for the correct diagram.



**Figure 12A — Wiring Diagram for 1-Speed, 115/230V - 1 Phase Models**

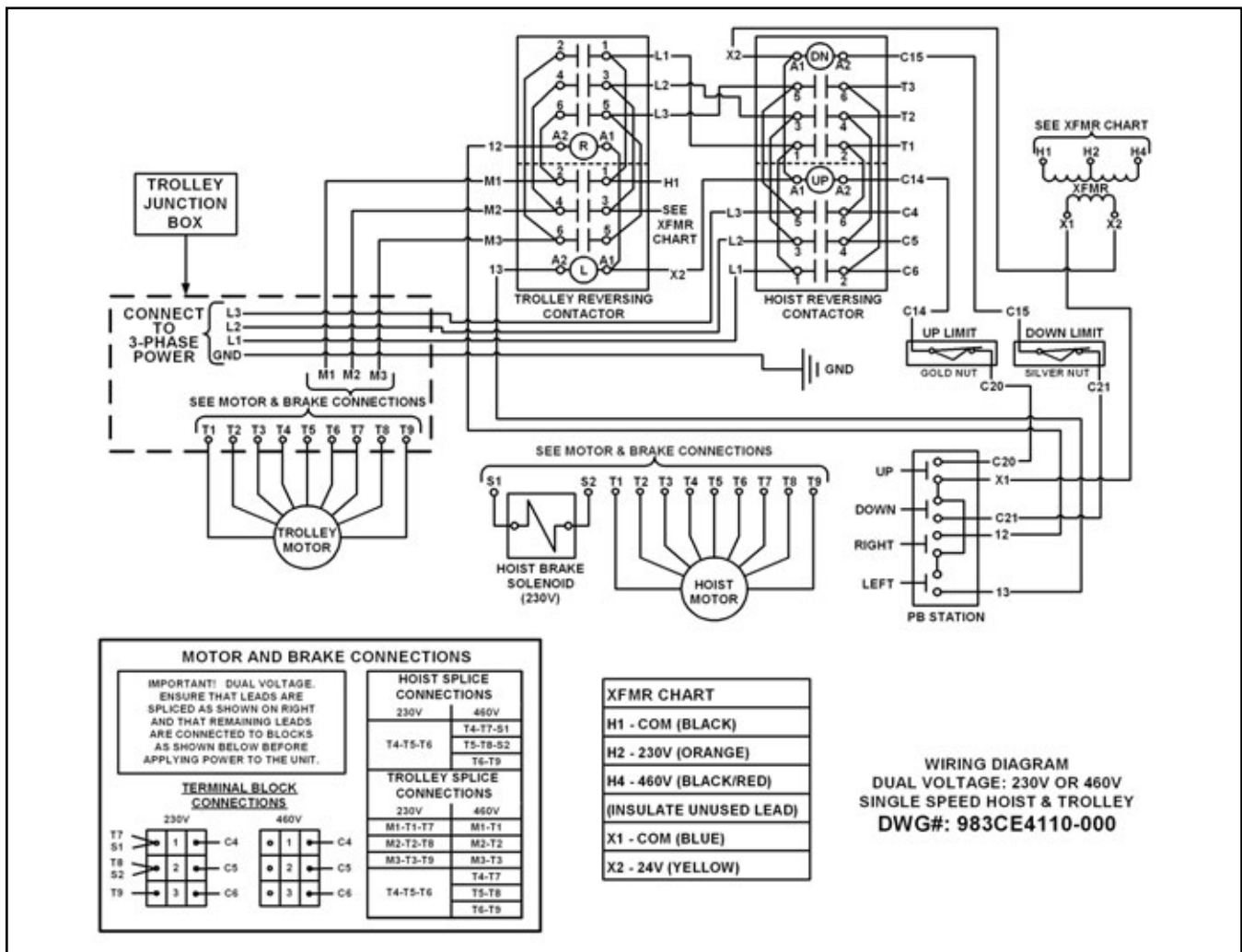
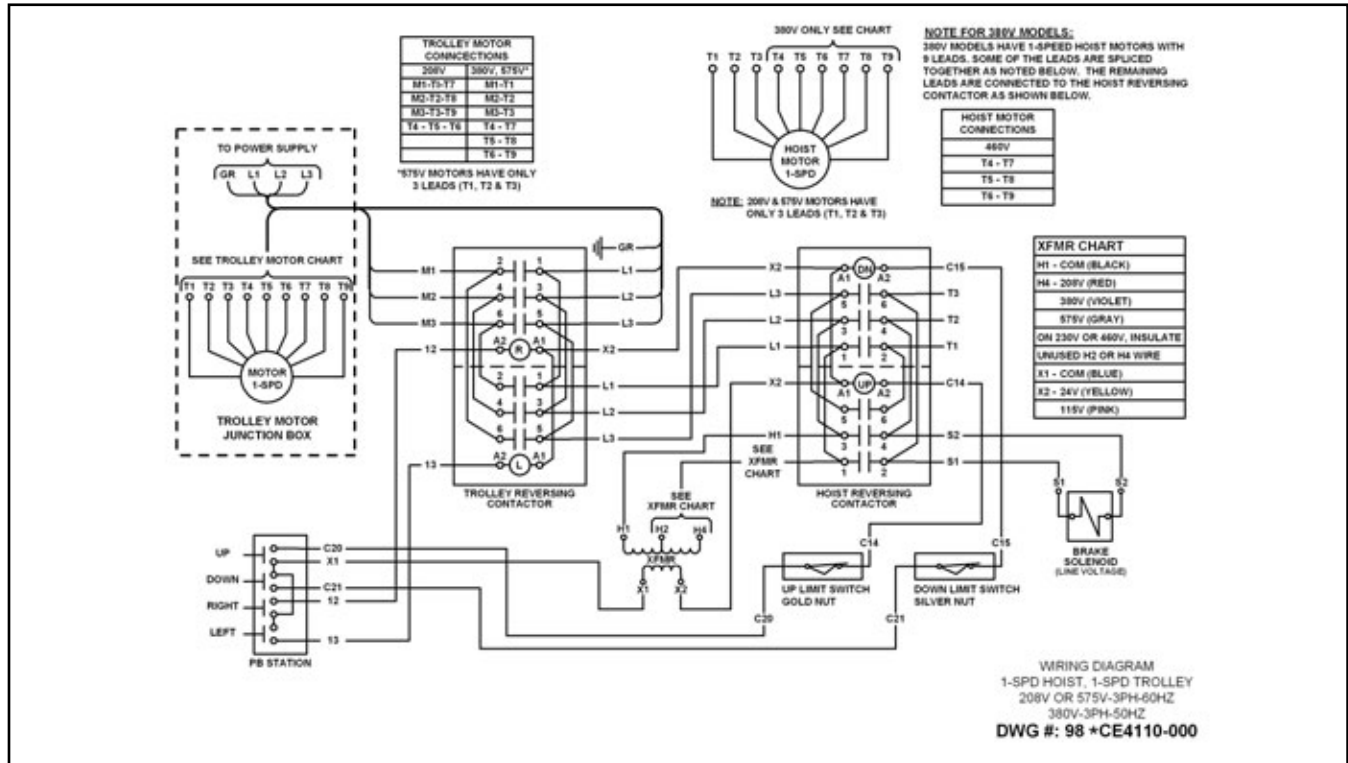
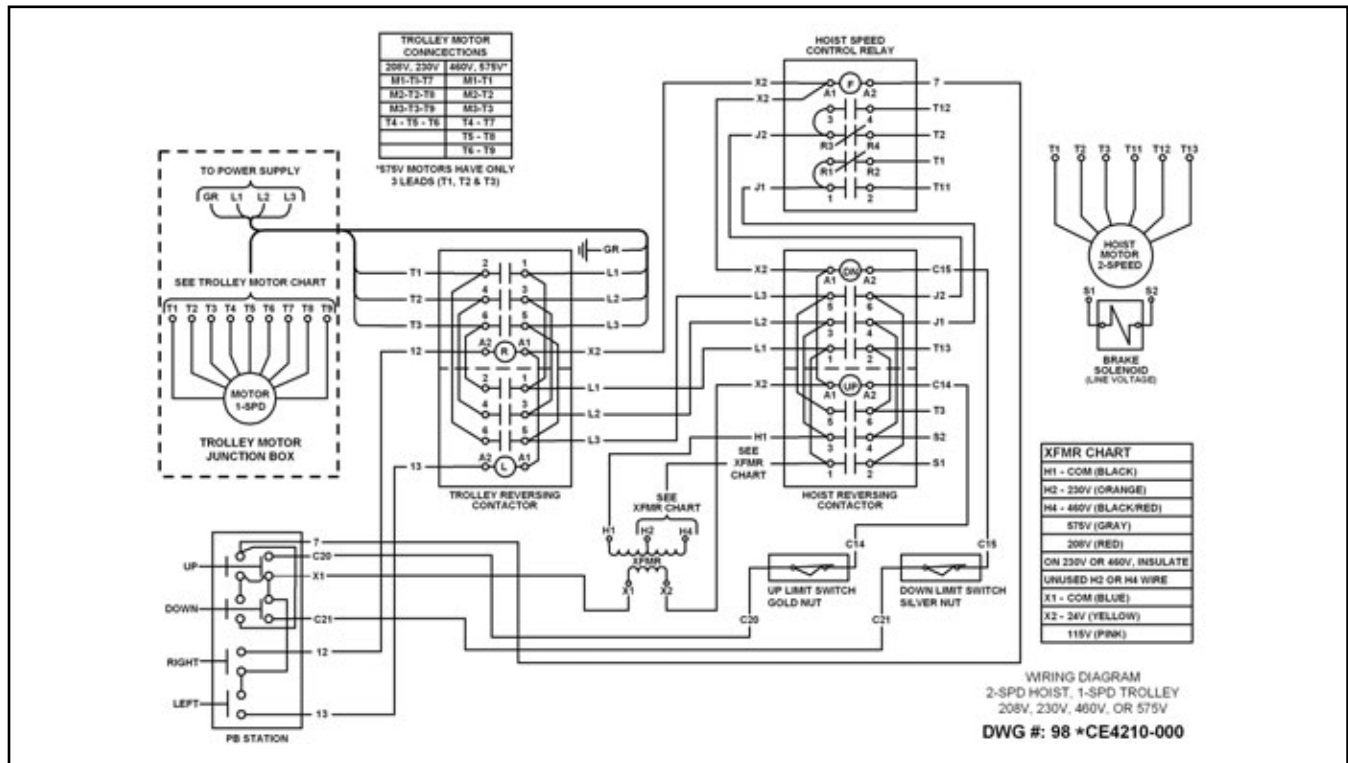

Figure 12B — Wiring Diagram for 1-Speed, 230/460V - 3 Phase - 60HZ Models



**Figure 12C — Wiring Diagram for 1-Speed Hoist, 1-Speed Trolley, 3 Phase Models**

\* Factory supplied wiring diagrams will have numbers beginning with 985 for 575V, 987 for 208V and 988 for 380V.



**Figure 12D — Wiring Diagram for 2-Speed Hoist, 1-Speed Trolley, 3 Phase Models**

\* Factory supplied wiring diagrams will have numbers beginning with 983 for 230 or 460V, 985 for 575V, 987 for 208V and 988 for 380V.

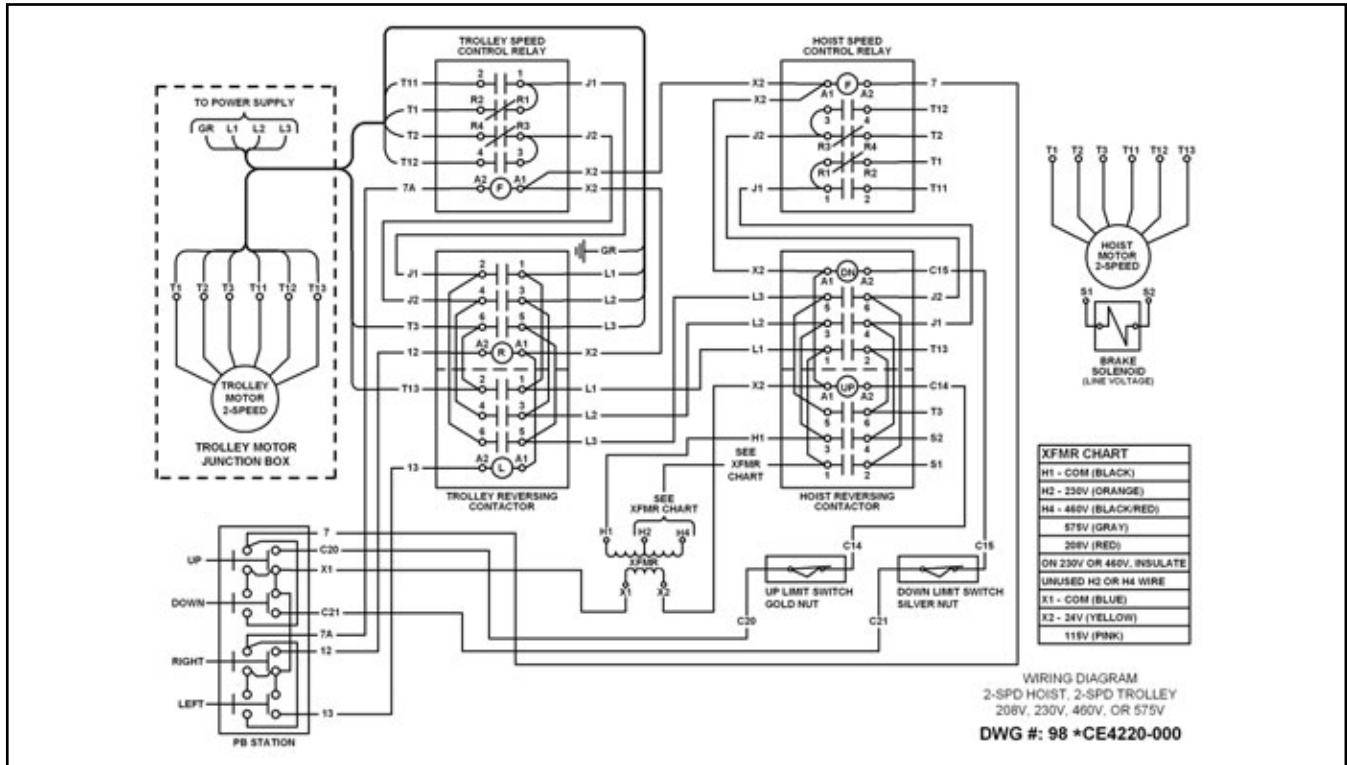

**Figure 12E — Wiring Diagram for 2-Speed Hoist, 2-Speed Trolley Models**

\* Factory supplied wiring diagrams will have numbers beginning with 983 for 230 or 460V, 985 for 575V, 987 for 208V and 988 for 380V.

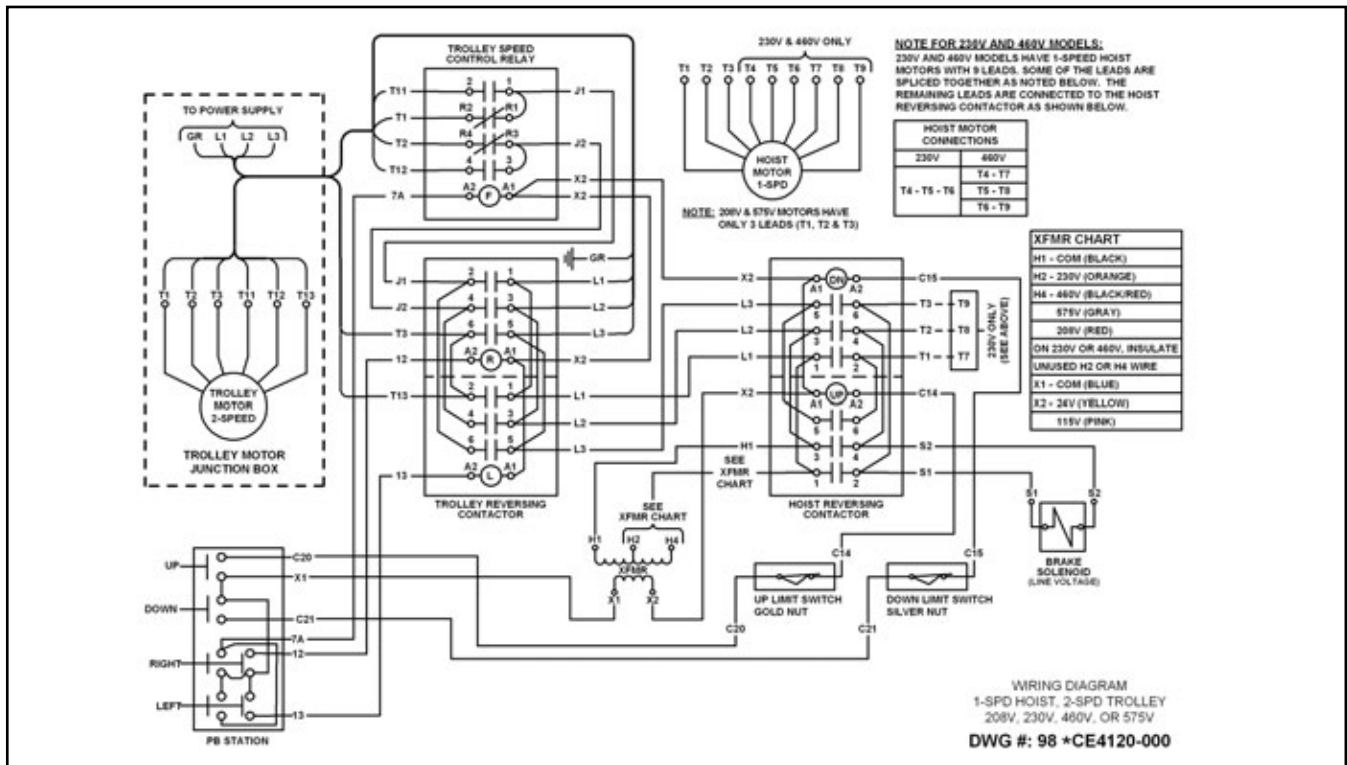

**Figure 12F — Wiring Diagram for 1-Speed Hoist, 2-Speed Trolley Models**

\* Factory supplied wiring diagrams will have numbers beginning with 983 for 230 or 460V, 985 for 575V, 987 for 208V and 988 for 380V.

## HOIST TROUBLE SHOOTING

Always disconnect unit from the power supply system before removing hoist covers or the back cover of control station.



### WARNING

**Failure to follow proper lockout/tagout procedures may present the danger of electrical shock.**

**TO AVOID INJURY:  
Disconnect power and lockout/tagout disconnecting means before removing cover or servicing this equipment.**

— Probable Cause —

— Remedy —

|   |   |
|---|---|
| <b>Hook fails to stop at end of travel</b>  |   |
| <ol style="list-style-type: none"> <li>Limit switch not operating</li> <li>Brass limit switch nuts not moving on shaft</li> <li>Hoist reversing contactor malfunctioning</li> </ol>   | <ol style="list-style-type: none"> <li>Check adjustment (See LIMIT SWITCH ADJUSTMENT, page 10). Check connections against wiring diagram. Tighten loose connections or replace.</li> <li>Check for stripped threads or bent nut guide.</li> <li>Remove electrical cover and check reversing contactor.</li> </ol>   |
| <b>Hoist does not respond to pushbutton</b>   |   |
| <ol style="list-style-type: none"> <li>Power failure in supply lines</li> <li>Wrong voltage or frequency</li> <li>Improper connections in hoist or pushbutton station</li> <li>Brake does not release</li> <li>Faulty hoist reversing contactor</li> </ol>  | <ol style="list-style-type: none"> <li>Check circuit breakers, switches and connections in power supply lines.</li> <li>Check voltage and frequency of power supply against the rating on the nameplate of the motor.</li> <li>Check all connections at line connectors and on terminal block. Check terminal block on dual voltage hoists for proper voltage connections.</li> <li>Check connections to the solenoid coil. Check for open or short circuit. Check for proper adjustment (See BRAKE ADJUSTMENT, page 11).</li> <li>Check coils for open or short circuit. Check all connections in control circuit. Check for burned contacts. Replace as needed.</li> </ol>  |
| <b>Hook does not stop promptly</b>  |   |
| <ol style="list-style-type: none"> <li>Hoist overloaded</li> <li>Brake not holding</li> </ol>   | <ol style="list-style-type: none"> <li>Reduce load to within rated capacity of hoist.</li> <li>Check brake adjustment (See BRAKE ADJUSTMENT, page 11). It may be necessary to replace discs.</li> </ol>   |
| <b>Hook moves in wrong direction</b>  |   |
| <ol style="list-style-type: none"> <li>Three phase reversal</li> <li>Improper connections</li> </ol>  | <ol style="list-style-type: none"> <li>Reverse any two wires (except the ground wire) at the power source (See ELECTRICAL CONNECTIONS, page 6).</li> <li>Check all connections against wiring diagram.</li> </ol>   |
| <b>Hoist hesitates to lift when energized</b>   |   |
| <ol style="list-style-type: none"> <li>Hoist overloaded</li> <li>Motor brake requires adjustment</li> <li>Worn overload limiting clutch</li> <li>Low voltage</li> <li>Faulty SINPAC® starting switch or start capacitor (single phase hoists only)</li> </ol>   | <ol style="list-style-type: none"> <li>Reduce load within rated capacity of hoist.</li> <li>Check motor brake adjustment (See BRAKE ADJUSTMENT, page 11).</li> <li>Replace clutch.</li> <li>Determine cause of low voltage and bring up to within plus or minus 10% of the voltage specified on the motor. Measure voltage at the hoist reversing contactor while lifting a load.</li> <li>Replace faulty component.</li> </ol>   |
| <b>Hook raises but will not lower</b>   |   |
| <ol style="list-style-type: none"> <li>"DOWN" circuit open</li> <li>Broken conductor in pushbutton cable</li> <li>Faulty hoist reversing contactor</li> <li>Loose screw clamps</li> </ol>   | <ol style="list-style-type: none"> <li>Check circuit for loose connections. Check "DOWN" limit switch for malfunction.</li> <li>Check each conductor in the cable. If one is broken, replace entire cable.</li> <li>Check coils for open or short circuit. Check all connections in control circuit. Check for burned contacts. Replace as needed.</li> <li>Ensure that screw clamps are tightened on the terminal blocks and reversing contactor.</li> </ol>   |
| <b>Hook lowers but will not raise</b>   |   |
| <ol style="list-style-type: none"> <li>Hoist overloaded</li> <li>Low voltage</li> <li>"UP" circuit open</li> <li>Broken conductor in pushbutton cable</li> <li>Faulty hoist reversing contactor</li> <li>Faulty capacitor (single phase hoist only)</li> <li>Worn overload limiting clutch</li> <li>Loose screw clamps</li> </ol> | <ol style="list-style-type: none"> <li>Reduce load to within rated capacity of hoist.</li> <li>Determine cause of low voltage and bring up to within plus or minus 10% of the voltage specified on the motor. Measure voltage at the hoist reversing contactor while lifting a load.</li> <li>Check circuit for loose connections. Check "UP" limit switch for malfunction.</li> <li>Check each conductor in the cable. If one is broken, replace entire cable.</li> <li>Check coils for open or short circuit, check all connections in control circuit. Check for burned contacts. Replace as needed.</li> <li>Check starting capacitor on motor. Replace if necessary.</li> <li>Replace overload clutch assembly.</li> <li>Ensure that screw clamps are tightened on the terminal blocks and reversing contactor.</li> </ol> |
| <b>Motor overheats</b>  |   |
| <ol style="list-style-type: none"> <li>Excessive load</li> <li>Low voltage</li> <li>Extreme external heating</li> <li>Frequent starting or reversing</li> <li>Brake dragging</li> </ol>   | <ol style="list-style-type: none"> <li>Reduce load to within rated capacity of hoist.</li> <li>Determine cause of low voltage and bring up to within plus or minus 10% of the voltage specified on the motor. Measure voltage at the hoist reversing contactor while lifting a load.</li> <li>As the ambient temperature rises towards the 130°F limitation of the unit, frequency of the hoist operation must be limited to avoid overheating of the motor. See ADVERSE ENVIRONMENTAL CONDITIONS, page 3.</li> <li>Excessive inching, jogging or reversing should be avoided since this type of operation will drastically shorten the life of motor, contactor and brake.</li> <li>Check brake adjustment (See BRAKE ADJUSTMENT, page 11).</li> </ol>   |

## HOIST TROUBLE SHOOTING CONTINUED

Always disconnect unit from the power supply system before removing hoist covers or the back cover of control station.

— Probable Cause —

— Remedy —

|   |   |
|---|---|
| <b>Lack of proper lifting speed</b>   |   |
| <ol style="list-style-type: none"> <li>1. Hoist overloaded</li> <li>2. Brake dragging</li> <li>3. Low voltage</li> <li>4. Overload limiting clutch intermittently slipping</li> </ol> | <ol style="list-style-type: none"> <li>1. Reduce load to within rated capacity of hoist.</li> <li>2. Check for proper brake adjustment or other defects.</li> <li>3. Ensure that the voltage at the reversing contactor is within <math>\pm 10\%</math> of the nominal voltage while lifting a load.</li> <li>4. Replace overload clutch assembly.</li> </ol> |
| <b>Motor brake noise or chatter (while starting hoist)</b>  |   |
| <ol style="list-style-type: none"> <li>1. Brake needs adjustment</li> <li>2. Low voltage</li> </ol>   | <ol style="list-style-type: none"> <li>1. See BRAKE ADJUSTMENT, page 11.</li> <li>2. Ensure that the voltage at the reversing contactor is within <math>\pm 10\%</math> of the nominal voltage while lifting a load.</li> </ol>   |
| <b>Motor brake "buzz" (anytime hoist is running)</b>  |   |
| <ol style="list-style-type: none"> <li>1. Brake needs adjustment</li> <li>2. Broken shading coil on brake frame</li> </ol>  | <ol style="list-style-type: none"> <li>1. See BRAKE ADJUSTMENT, page 11.</li> <li>2. Replace shading coil or complete brake frame assembly.</li> </ol>  |

## TROLLEY TROUBLE SHOOTING

— Probable Cause —

— Remedy —

|   |   |
|---|---|
| <b>Trolley does not operate</b>   |   |
| <ol style="list-style-type: none"> <li>1. No voltage at trolley</li> <li>2. Open control circuit</li> <li>3. Wrong voltage or frequency</li> <li>4. Low voltage</li> <li>5. Excessive load</li> <li>6. Faulty SINPAC<sup>®</sup> starting switch or start capacitor (single phase trolleys only)</li> </ol> | <ol style="list-style-type: none"> <li>1. Mainline or branch circuit switch open; branch line fuse blown or circuit breaker tripped. Close, replace or re-set. Check for grounded or open connections in supply lines or current collectors.</li> <li>2. Open or shorted windings in transformer or reversing contactor; control station switch contacts not making contact; loose connection or broken wire circuit. Check continuity and repair or replace defective parts.</li> <li>3. Check voltage and frequency of power supply against the rating on the nameplate of the motor.</li> <li>4. Ensure that the voltage at the trolley contactor does not drop below 10% of the nominal voltage.</li> <li>5. Reduce load to within rated capacity of unit.</li> <li>6. Replace faulty component.</li> </ol> |
| <b>Trolley operates in one direction only</b>   |   |
| <ol style="list-style-type: none"> <li>1. Open control circuit</li> </ol>   | <ol style="list-style-type: none"> <li>1. Open or shorted windings in transformer or reversing contactor; control station switch contacts not making contact; loose connection or broken wire in circuit. Check continuity and repair or replace defective parts.</li> </ol>  |
| <b>Trolley operates sluggishly</b>  |   |
| <ol style="list-style-type: none"> <li>1. Excessive load</li> <li>2. Low voltage</li> <li>3. Worn or dirty rails</li> </ol>   | <ol style="list-style-type: none"> <li>1. Reduce load to within rated capacity of hoist.</li> <li>2. Ensure that the voltage at the trolley contactor does not drop below 10% of the nominal voltage.</li> <li>3. Clean rails, inspect for worn spots.</li> </ol>   |
| <b>Motor overheats</b>  |   |
| <ol style="list-style-type: none"> <li>1. Excessive load</li> <li>2. Low voltage</li> <li>3. Extreme external heating</li> <li>4. Frequent starting or reversing</li> </ol>   | <ol style="list-style-type: none"> <li>1. Reduce load to within rated capacity of hoist.</li> <li>2. Ensure that the voltage at the trolley contactor does not drop below 10% of the nominal voltage.</li> <li>3. As the ambient temperature rises towards the 130°F limitation of the unit, frequency of trolley operation must be limited to avoid overheating of motor. See ADVERSE ENVIRONMENTAL CONDITIONS, page 3.</li> <li>4. Excessive inching, jogging or plugging should be avoided since this type of operation will drastically shorten the life of motor and contactor. Always allow the trolley to coast to a stop before reversing its direction.</li> </ol>   |

**INSPECTION AND MAINTENANCE CHECK LIST  
ELECTRIC POWERED OVERHEAD CHAIN HOIST**

Type of Hoist \_\_\_\_\_ Capacity (Tons) \_\_\_\_\_  
Location \_\_\_\_\_ Original Installation Date \_\_\_\_\_  
Manufacturer \_\_\_\_\_ Manufacturer's Serial No. \_\_\_\_\_

| Item  | Frequency of Inspection |         |          | Possible Deficiencies  | OK | Action Required |
|---|-------------------------|---------|----------|--|----|-----------------|
|   | Frequent                |         | Periodic |  |    |                 |
|   | Daily                   | Monthly | 1-12 Mo. |  |    |                 |
| Operating Controls  | *                       | *       | *        | Any deficiency causing improper operation  |    |                 |
| Limit Switches  | *                       | *       | *        | 1. Any deficiency causing improper operation<br>2. Switch sticks or does not open circuit when tripped.  |    |                 |
| Motor Brake   | *                       | *       | *        | 1. Slippage or excessive drift<br>2. Glazing, contamination or excessive wear  |    |                 |
| Hooks   | *                       | *       | *        | Excessive throat opening 15% bent or twisted more than 10 degrees, damaged hook latch, wear, chemical damage, worn hook bearing. Cracks (use dye penetrant, magnetic or other suitable detection method) |    |                 |
| Suspension Lug  | *                       | *       | *        | Cracks, excessive wear or other damage which may impair the strength of the lug. Cracks (use dye penetrant, magnetic particle or other suitable detection method)  |    |                 |
| Chain   | *                       | *       | *        | Inadequate lubrication, excessive wear or stretch, cracked, damaged or twisted links, corrosion or foreign substance   |    |                 |
| Hook and Suspension Lug Connections   |                         |         | *        | Cracks, bending, stripped threads  |    |                 |
| Pins, Bearings, Bushings Shafts, Couplings, Chain Guides                    |                         |         | *        | Excessive wear, corrosion, cracks, distortion  |    |                 |
| Nuts, Bolts, Screws   |                         |         | *        | Looseness, stripped and damaged threads, corrosion   |    |                 |
| Load Sheaves  |                         |         | *        | Distortion, cracks, and excessive wear. Build-up of foreign substances   |    |                 |
| Housings, Load Block  |                         |         | *        | Cracks, distortion. Excessive wear, internal build-up of foreign substances  |    |                 |
| Wiring and Terminals  |                         |         | *        | Fraying, defective insulation  |    |                 |
| Contact Block, Reversing Contactors, other Electrical Apparatus & Terminals |                         |         | *        | Loose connections, burned or pitted contacts   |    |                 |
| Supporting Structure and Trolley  |                         |         | *        | Damage or wear which restricts ability to support imposed loads  |    |                 |
| Nameplates, Decals, Warning Labels  |                         |         | *        | Missing, damaged or illegible  |    |                 |
| Gear Oil  |                         |         | *        | Low level or needs changing  |    |                 |

**NOTE:** Refer to Maintenance and Inspection Sections of the Hoist-Maintenance Manual for further details.

**FREQUENCY OF INSPECTION**

Frequent — Indicates items requiring inspection daily to monthly. Daily inspections may be performed by the operator if properly designated.  
Periodic — Indicates items requiring inspection monthly to yearly. Inspections to be performed by or under the direction of a properly designated period. The exact period of inspection will depend on frequency and type of usage. Determination of this period will be based on the user's experience. It is recommended that the user begin with a monthly inspection and extend the periods to quarterly, semi-annually or annually based on user's monthly experience.

**Figure 13A — Recommended Inspection and Maintenance Check List**

**NOTE:** This inspection and maintenance check list is in accordance with our interpretation of the requirements of the Safety Standard for Overhead Hoists ASME B30.16. It is, however, the ultimate responsibility of the employer/user to interpret and adhere to the applicable requirements of this safety standard.



| INSPECTOR'S REPORT    |  |             |      |
|-----------------------|--|-------------|------|
| ITEM                  | REMARKS (LIST DEFICIENCIES AND RECOMMENDED ACTION) |             |      |
|                       |  |             |      |
|                       |  |             |      |
|                       |  |             |      |
|                       |  |             |      |
|                       |  |             |      |
|                       |  |             |      |
|                       |  |             |      |
|                       |  |             |      |
|                       |  |             |      |
|                       |  |             |      |
|                       |  |             |      |
|                       |  |             |      |
| Inspector's Signature | Date Inspected                                     | Approved by | Date |

**Figure 13B — Recommended Inspector's Report**

| RECOMMENDED LUBRICATION SCHEDULE*<br>COFFING ELECTRIC POWERED CHAIN HOIST |   |  |  |         |            |
|---|---|--|--|---------|------------|
| PAGE AND REFERENCE NO.  | COMPONENT                               | TYPE OF LUBRICANT                          | TYPE OF SERVICE AND FREQUENCY OF LUBRICATION |         |            |
|   |   |  | HEAVY  | NORMAL  | INFREQUENT |
| Pages 40 & 41<br>Ref. No. 18  | Load Chain                              | SAE 90 gear oil                            | Daily  | Weekly  | Monthly    |
| Page 40 & 41  | Gearing                                 | SAE 90 Extreme Pressure (EP) gear oil      | At periodic inspection (see Figure 13A)      |         |            |
| Page 38 & 39<br>Ref. No. 9 & 7  | Limit Switch Shaft                      | multi-purpose oil or general purpose spray | Monthly                                      | Yearly  | Yearly     |
| Pages 42 & 43<br>Ref. No. 38, 50  | Load Hook Bearing                       | SAE 30 gear oil                            | Weekly                                       | Monthly | Yearly     |
| Pages 42 & 43<br>Ref. No. 44  | Idler Sheave Bearing (Bushing) Assembly | Multipurpose lithium base bearing grease   | At periodic inspection (see Figure 13A)      |         |            |

**NOTE:** All bearings except hook and idler sheave bearings are prelubricated and sealed.  
(\*) This lubrication schedule is based on a hoist operating in normal environment conditions. Hoists operating in adverse atmospheres containing excessive heat, corrosive fumes or vapors, abrasive dust, etc., should be lubricated more frequently.

**Figure 14 — Recommended Lubrication Schedule**

Contact your nearest Coffing Service Center for parts and service. For a complete list, see pages 50 and 51. Please have the hoist model number, serial number, and part number with description available for reference.

## Figure 15 - Basic Hoist

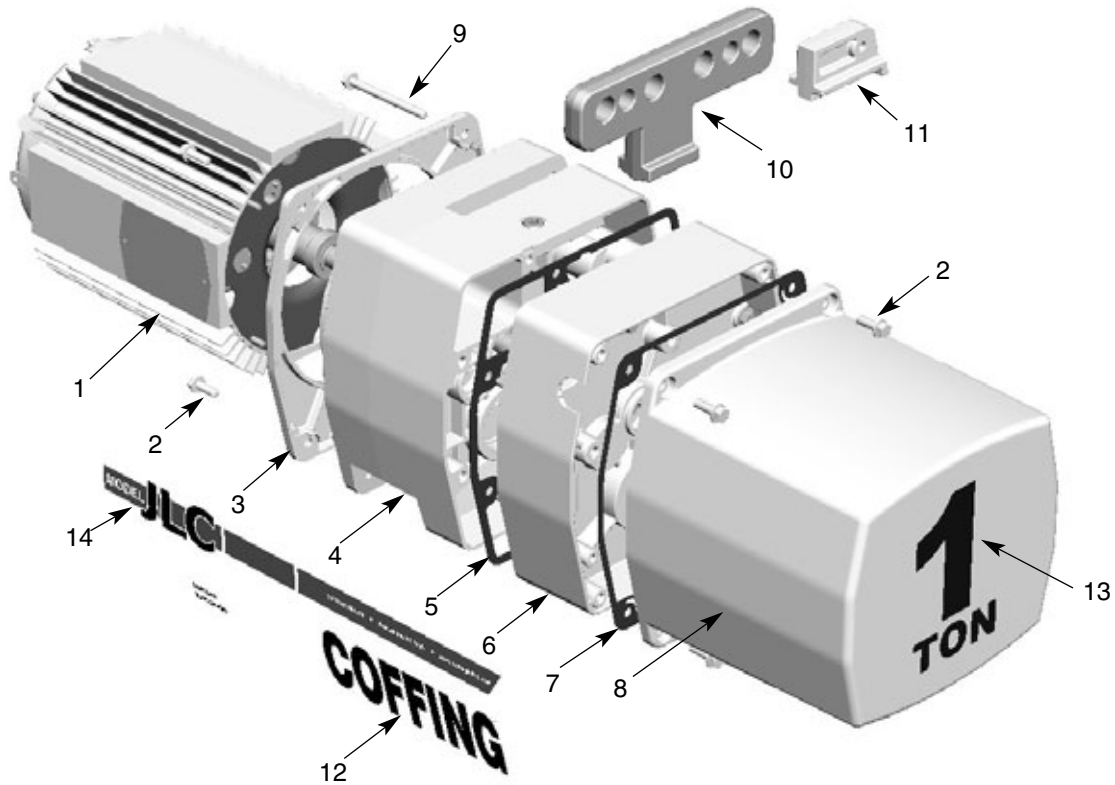

### Parts List for Basic Hoist

| Ref No. | Description                    | Part No.   | Qty | Ref No. | Description                            | Part No. | Qty |
|---------|--------------------------------|------------|-----|---------|--|----------|-----|
| 1       | Motor<br>(See Figures 16 & 17) | —          | 1   | 14      | JLC Strip Decal<br>(Left & Right Side) | JLC677   | 1   |
| 2       | Cover Screw                    | H2976P     | 7   | △       | Nylon Cover                            |          |     |
| 3       | Trim Cover                     | JM37       | 1   |         | †1/8 ton                               | 08790W   | 1   |
| 4       | Transmission Housing           | JM3533     | 1   |         | †1/4 ton                               | 08791W   | 1   |
| 5       | Transmission Case Gasket       | JM560      | 1   |         | †1/2 ton                               | 08792W   | 1   |
| 6       | Transmission Cover             | JM34       | 1   |         | †1 ton                                 | 08793W   | 1   |
| 7       | Electrical Cover Gasket        | JM563      | 1   |         | †2 ton                                 | 08794W   | 1   |
| 8       | Electrical Cover               | JM36       | 1   | △       | Suspension Lug                         |          |     |
| 9       | Hook Retainer Screw            | H2709P     | 1   |         | Cross Mounted (Standard)               | JM50C    | 1   |
| 10      | Suspension Lug Assembly        | JM50C      | 1   |         | Parallel Mounted                       | 50JM1    | 1   |
| 11      | Lug Retainer                   | JM285      | 1   |         |  |          |     |
| 12      | Coffing Decal                  | 677J7      | 2   |         |  |          |     |
| 13      | Capacity Decal                 |            |     |         |  |          |     |
|         | 1/8 ton                        | JLC675K-01 | 1   |         |  |          |     |
|         | 1/4 ton                        | JLC675K-02 | 1   |         |  |          |     |
|         | 1/2 ton                        | JLC675K-05 | 1   |         |  |          |     |
|         | 1 ton                          | JLC675K-10 | 1   |         |  |          |     |
|         | 2 ton                          | JLC675K-20 | 1   |         |  |          |     |

(△) Not Shown

Contact your nearest Coffing Service Center for parts and service. For a complete list, see pages 50 and 51. Please have the hoist model number, serial number, and part number with description available for reference.

## Figure 16 - Hoist Motor, 1-Speed, 1-Phase

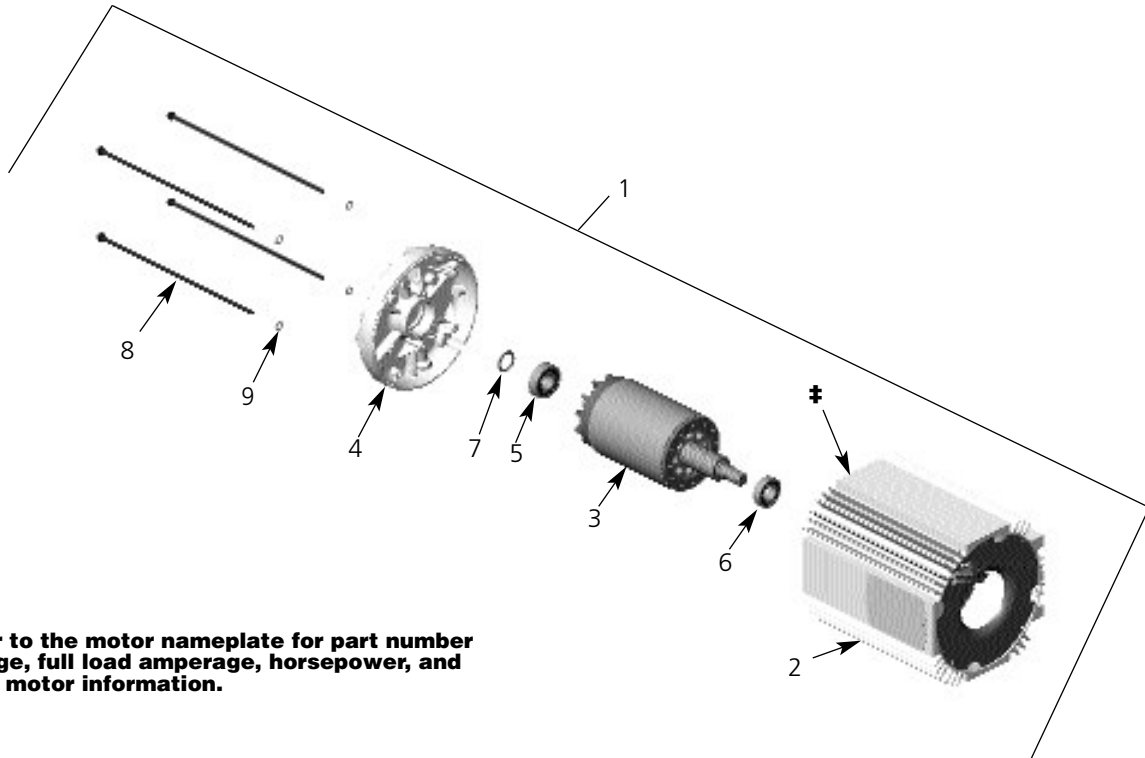

(‡) Refer to the motor nameplate for part number voltage, full load amperage, horsepower, and other motor information.

### Parts List for Hoist Motor, 1-Speed, 1-Phase

| Ref No. | Description          | Part No.    | Qty | Ref No. | Description           | Part No.  | Qty |
|---------|----------------------|-------------|-----|---------|-----------------------|-----------|-----|
| 1       | Hoist Motor          |             |     | 5       | Rear Bearing          | 500K3     | 1   |
|         | 1/4 hp, 115/230V-1Ph | 861JX11     | 1   | 6       | Front Bearing         | 732012C   | 1   |
|         | 1/2 hp, 115/230V-1Ph | 861JX12     | 1   | 7       | Shim Washer           | JL4301-01 | 1   |
|         | 1 hp, 115/230V-1Ph   | 861JX14     | 1   | 8       | Thru Bolt             | HA3100A56 | 4   |
| 2       | Stator Assembly      | *           | 1   | 9       | #10 Spring Lockwasher | H4082P    | 4   |
| 3       | Rotor Assembly       | *           | 1   |         |                       |           |     |
| 4       | End Shield           | 35EP3100D15 | 1   |         |                       |           |     |

\* Not available as an individual part.

Contact your nearest Coffing Service Center for parts and service. For a complete list, see pages 50 and 51. Please have the hoist model number, serial number, and part number with description available for reference.

## Figure 17 - Hoist Motor, 3-Phase

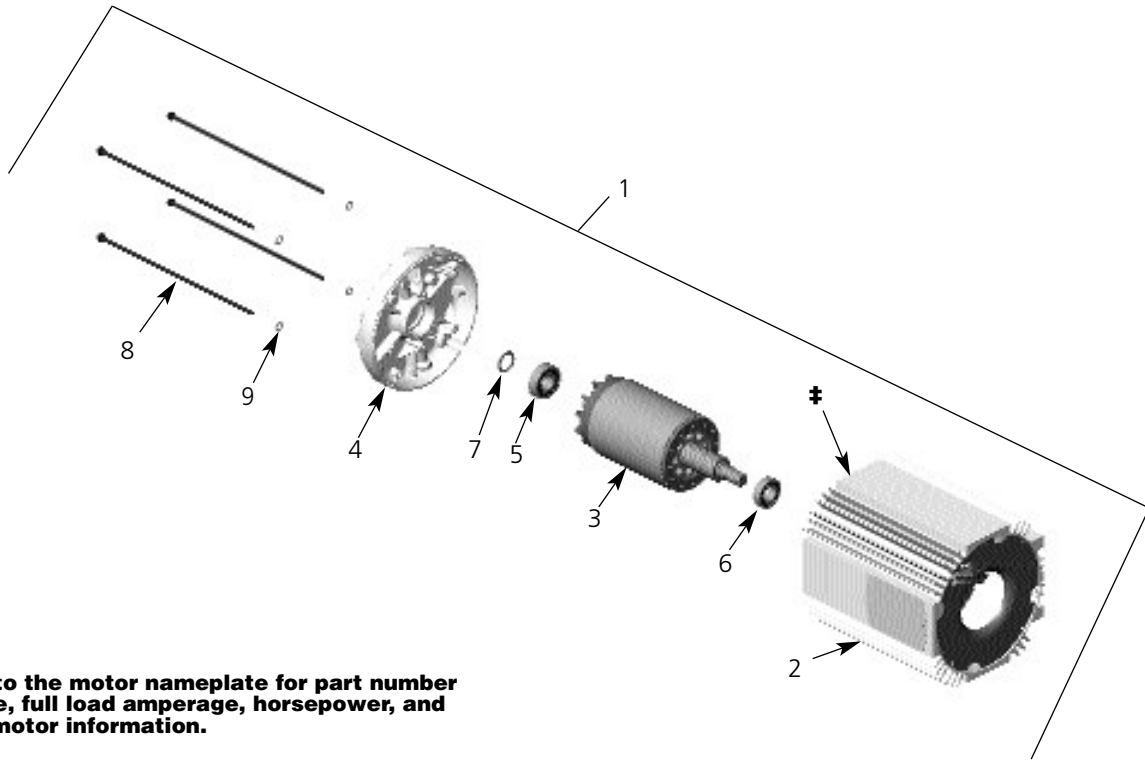

(‡) Refer to the motor nameplate for part number, voltage, full load amperage, horsepower, and other motor information.

| Ref No. | Description                  | Part No. | Qty | Ref No. | Description           | Part No.    | Qty |
|---------|------------------------------|----------|-----|---------|-----------------------|-------------|-----|
| 1       | <b>Hoist Motor (1-Speed)</b> |          |     |         | 1 hp, 575V-3Ph-60Hz   | 873JX12     | 1   |
|         | 1/4 hp, 230/460V-3Ph-60Hz    | 863JX1   | 1   |         | 1/4 hp, 208V-3Ph-60Hz | 873JX13     | 1   |
|         | 1/2 hp, 230/460V-3Ph-60Hz    | 863JX2   | 1   |         | 1/2 hp, 208V-3Ph-60Hz | 873JX14     | 1   |
|         | 1 hp, 230/460V-3Ph-60Hz      | 863JX4   | 1   |         | 1 hp, 208V-3Ph-60Hz   | 873JX16     | 1   |
|         | 1/4 hp, 575V-3Ph-60Hz        | 863JX5   | 1   | 2       | Stator Assembly       | *           | 1   |
|         | 1/2 hp, 575V-3Ph-60Hz        | 863JX6   | 1   | 3       | Rotor Assembly        | *           | 1   |
|         | 1 hp, 575V-3Ph-60Hz          | 863JX8   | 1   | 4       | End Shield            | 35EP3100D15 | 1   |
|         | 1/4 hp, 208V-3Ph-60Hz        | 863JX9   | 1   | 5       | Rear Bearing          | 500K3       | 1   |
|         | 1/2 hp, 208V-3Ph-60Hz        | 863JX10  | 1   | 6       | Front Bearing         | 732012C     | 1   |
|         | 1 hp, 208V-3Ph-60Hz          | 863JX12  | 1   | 7       | Shim Washer           | JL4301-01   | 1   |
|         | <b>Hoist Motor (2-Speed)</b> |          |     | 8       | Thru Bolt (1-Speed)   | HA3100A56   | 4   |
|         | 1/4 hp, 230V-3Ph-60Hz        | 873JX1   | 1   |         | Thru Bolt (2-Speed)   | HA3100A71   | 4   |
|         | 1/2 hp, 230V-3Ph-60Hz        | 873JX2   | 1   | 9       | #10 Spring Lockwasher | H4082P      | 4   |
|         | 1 hp, 230V-3Ph-60Hz          | 873JX4   | 1   |         |                       |             |     |
|         | 1/4 hp, 460V-3Ph-60Hz        | 873JX5   | 1   |         |                       |             |     |
|         | 1/2 hp, 460V-3Ph-60Hz        | 873JX6   | 1   |         |                       |             |     |
|         | 1 hp, 460V-3Ph-60Hz          | 873JX8   | 1   |         |                       |             |     |
|         | 1/4 hp, 575V-3Ph-60Hz        | 873JX9   | 1   |         |                       |             |     |
|         | 1/2 hp, 575V-3Ph-60Hz        | 873JX10  | 1   |         |                       |             |     |

\* Not available as an individual part.

Contact your nearest Coffing Service Center for parts and service. For a complete list, see pages 50 and 51. Please have the hoist model number, serial number, and part number with description available for reference.

## Figure 18 - Brake & Solenoid Parts

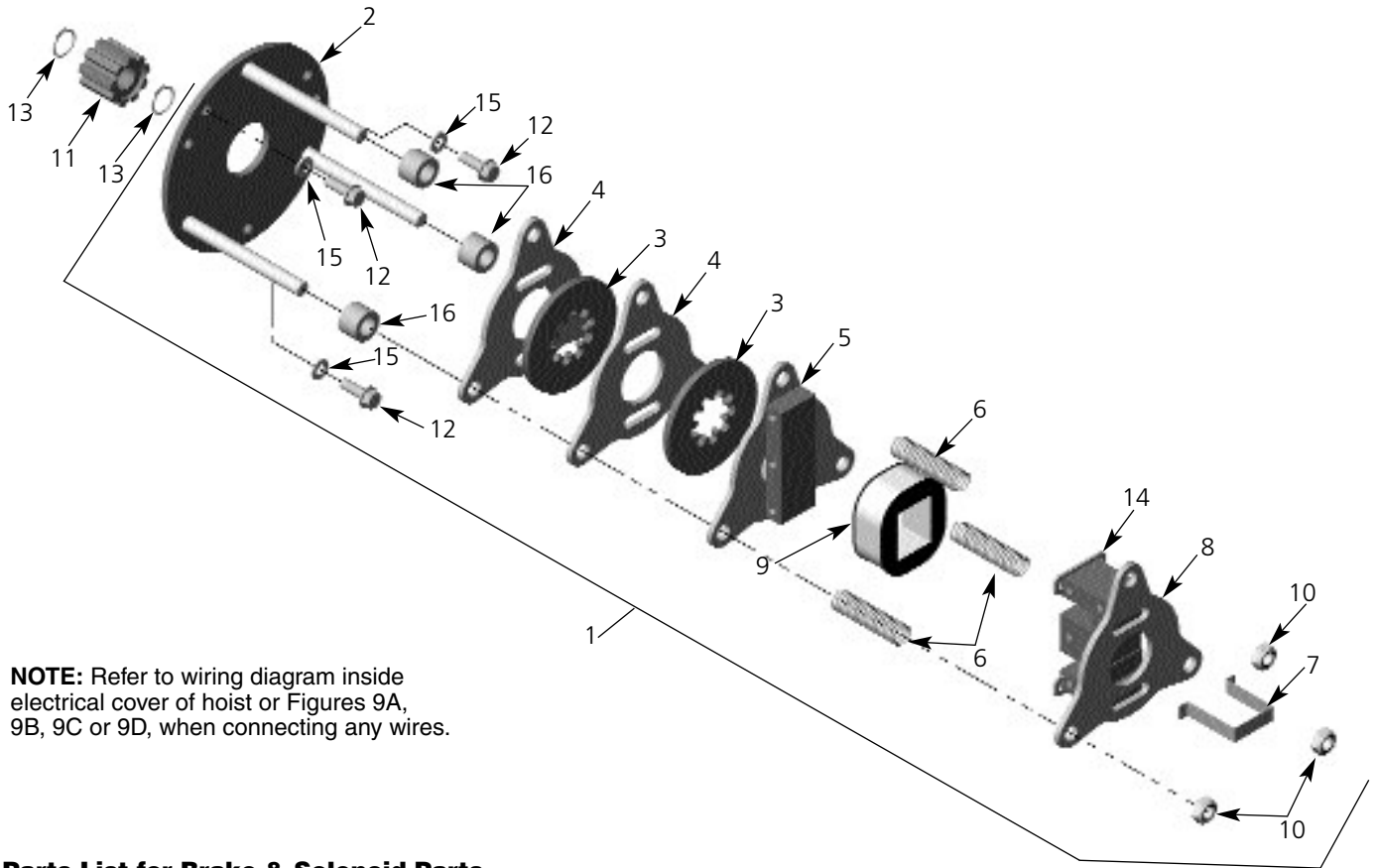

**NOTE:** Refer to wiring diagram inside electrical cover of hoist or Figures 9A, 9B, 9C or 9D, when connecting any wires.

### Parts List for Brake & Solenoid Parts

| Ref No. | Description               | Part No. | Qty | Ref No. | Description             | Part No. | Qty |
|---------|---------------------------|----------|-----|---------|-------------------------|----------|-----|
| 1       | Disc Brake Assembly*      |          |     | 9       | Brake Coil*             |          |     |
|         | 1 hp, 115 Volt            | 854JM1   | 1   |         | 115V*                   | 853JL1   | 1   |
|         | 1/4 & 1/2 hp, 115 Volt    | 854JM12  | 1   |         | 230V*                   | 853JL2   | 1   |
|         | 1 hp, 230 Volt            | 854JM2   | 1   |         | 460V                    | 853JL3   | 1   |
|         | 1/4 & 1/2 hp, 230 Volt    | 854JM22  | 1   |         | 575V                    | 853JL4   | 1   |
|         | 1 hp, 460 Volt            | 854JM3   | 1   |         | 208V                    | 853JL5   | 1   |
|         | 1/4 & 1/2 hp, 460 Volt    | 854JM32  | 1   | 10      | Locknut                 | H3978    | 3   |
|         | 1 hp, 575 Volt            | 854JM4   | 1   | 11      | Adapter                 | JM142    | 1   |
|         | 1/4 & 1/2 hp, 575 Volt    | 854JM42  | 1   | 12      | Screw                   | H2976P   | 3   |
|         | 1 hp, 208 Volt            | 854JM5   | 1   | 13      | Retaining Ring          | H5501    | 2   |
|         | 1/4 & 1/2 hp, 208 Volt    | 854JM52  | 1   | 14      | Shading Coil            | 860J1    | 2   |
| 2       | Plate & Stud Assembly     | 859JG1   | 1   |         | Shading Coil Adhesive   | H7812    | 1   |
| 3       | Brake Disc                |          |     | 15      | Lockwasher              | H4134    | 3   |
|         | 1/4 & 1/2 hp              | 581J1A   | 2   | 16      | Spacer for 1/4 & 1/2 hp | 141J2    | 3   |
|         | 1 hp                      | 581J1A   | 3   |         |                         |          |     |
| 4       | Brake Plate               | JF291    | 2   |         |                         |          |     |
| 5       | Plate & Armature Assembly | JF858    | 1   |         |                         |          |     |
| 6       | Spring                    | 344J6    | 3   |         |                         |          |     |
| 7       | Retainer                  | JF710    | 1   |         |                         |          |     |
| 8       | Plate & Frame Assembly    | JF857    | 1   |         |                         |          |     |

\* Dual-voltage 115/230V models use 115V Brake Assembly and Coil.  
Dual-voltage 230/460V models use 230V Brake Assembly and Coil.

Contact your nearest Coffing Service Center for parts and service. For a complete list, see pages 50 and 51. Please have the hoist model number, serial number, and part number with description available for reference.

## Figure 19 - Electrical Parts 1-Speed Hoist with 1-Speed Trolley Models

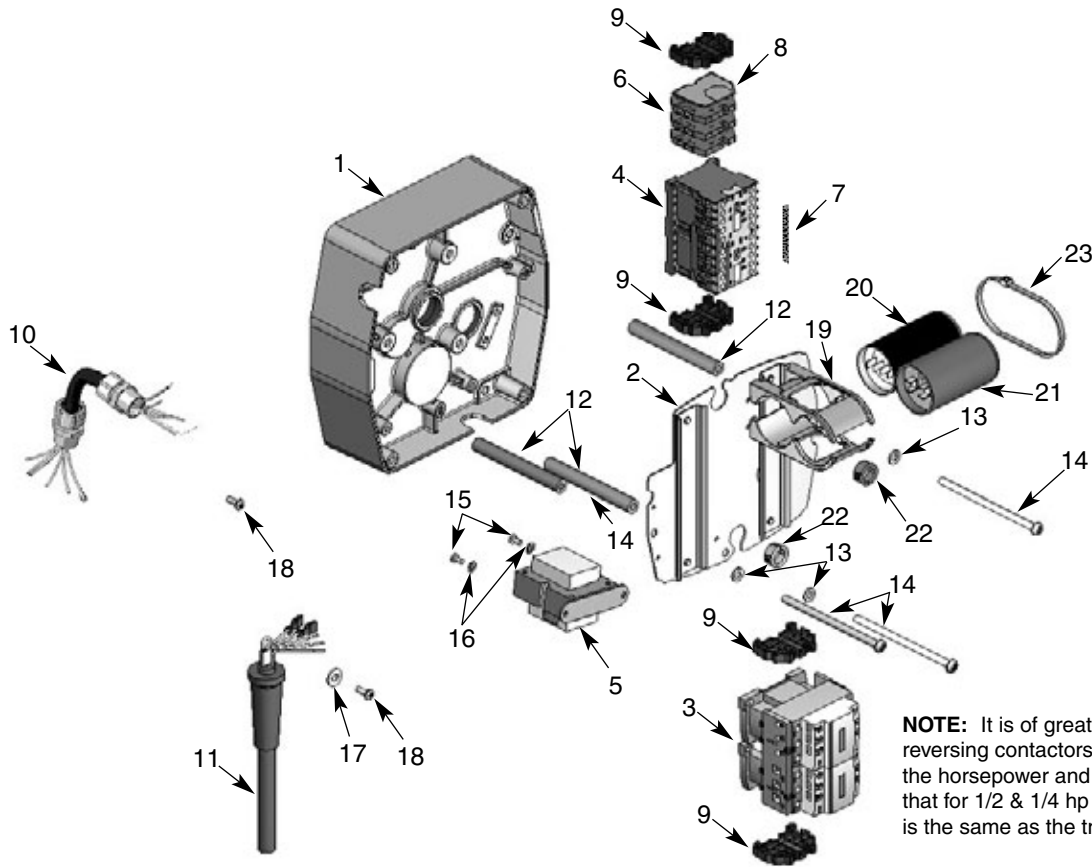

**NOTE:** It is of great importance that the hoist reversing contactors are replaced according to the horsepower and voltage of the hoist. Note that for 1/2 & 1/4 hp hoists, the hoist contactor is the same as the trolley contactor.

### Parts List for Electrical Parts, 1-Speed, 1-Speed

| Ref No. | Description                  | Part No. | Qty | Ref No.               | Description                    | Part No. | Qty |
|---------|------------------------------|----------|-----|-----------------------|--------------------------------|----------|-----|
| 1       | Gear Box Cover               | JM34     | 1   | 7                     | Marking Strip                  | 909J11   | 1   |
| 2       | Panel Plate                  | 257JM200 | 1   | 8                     | End Plate                      |          |     |
| 3       | Hoist Reversing Contactor*   |          |     | 115/230V, 1-Phase     | 909J12                         | 1        |     |
|         | 1/2 hp & 1/4 hp:             |          |     | 3-Phase               | 909J15                         | 1        |     |
|         | 24V Coil                     | 28860    | 1   | 9                     | End Clamp                      | 909J13   | 4   |
|         | 115V Coil                    | 24799    | 1   | 10                    | Tie Cable Assembly             |          |     |
|         | 1 hp, 115/230V-1 Phase:      |          |     | 115/230V-1 Phase      | 955JG48-1                      | 1        |     |
|         | 24V Coil                     | 24791    | 1   | 3-Phase               | 955JG48                        | 1        |     |
|         | 115V Coil                    | 28905    | 1   | 11                    | PB & Cable Assembly            | —        | 1   |
|         | 1 hp, 3-Phase:               |          |     | (See Figures 22 - 24) |                                |          |     |
|         | 24V Coil                     | 25943    | 1   | 12                    | Panel Standoff                 | 200J4    | 3   |
|         | 115V Coil                    | 24729    | 1   | 13                    | 1/4" Internal-tooth Lockwasher | H4134    | 3   |
| 4       | Trolley Reversing Contactor* |          |     | 14                    | 1/4-20UNC X 4" Screw           | H1027P   | 3   |
|         | 24V Coil                     | 28860    | 1   | 15                    | 8-32UNC X 5/16" Screw          | H2751    | 2   |
|         | 115V Coil                    | 24799    | 1   | 16                    | #8 External-tooth Lockwasher   | H4158    | 2   |
| 5       | Transformer*                 |          |     | 17                    | 1/4" Flatwasher                | H4002P   | 1   |
|         | Pri.: 115/230V, Sec.: 24V    | 821J412  | 1   | 18                    | 10-24UNC X 1/2" Screw          | H2970    | 2   |
|         | Pri.: 115/230V, Sec.: 115V   | 821J411  | 1   | 19†                   | Can Mounting Bracket           | JM811    | 2   |
|         | Pri.: 230/460V, Sec.: 24V    | 821J432  | 1   | 20†                   | SINPAC® Starting Switch        | 839J3    | 1   |
|         | Pri.: 230/460V, Sec.: 115V   | 821J431  | 1   | 21†                   | Capacitor                      | JL810-4  | 1   |
|         | Pri.: 575V, Sec.: 24V        | 821J452  | 1   | 22                    | Grommet                        | H9086    | 2   |
|         | Pri.: 575V, Sec.: 115V       | 821J451  | 1   | 23                    | Tie Strap                      | H9087    | 1   |
|         | Pri.: 208V, Sec.: 24V        | 821J472  | 1   |                       |                                |          |     |
|         | Pri.: 208V, Sec.: 115V       | 821J471  | 1   |                       |                                |          |     |
| 6       | Terminal Block               |          |     |                       |                                |          |     |
|         | 115/230V, 1-Phase            | 909J10   | 3   |                       |                                |          |     |
|         | 3-Phase                      | 909J14   | 3   |                       |                                |          |     |

\* **Coil voltage of the contactor and the secondary voltage of the transformer must be the same. This is referred to as the control voltage. Standard units are supplied with 24V Control.**  
 † **Single Phase Only.**

Contact your nearest Coffing Service Center for parts and service. For a complete list, see pages 50 and 51. Please have the hoist model number, serial number, and part number with description available for reference.

## Figure 20 - Electrical Parts 2-Speed Hoist, 1-Speed Trolley

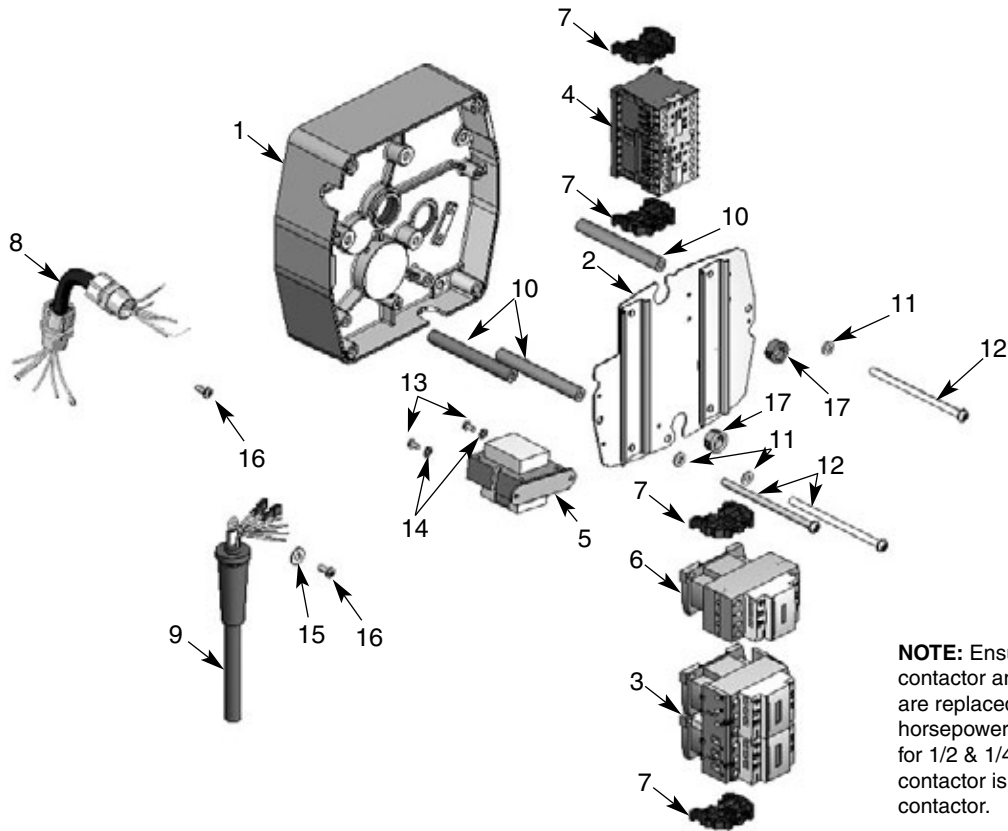

**NOTE:** Ensure that hoist reversing contactor and speed control relay are replaced according to the horsepower of the hoist. Note that for 1/2 & 1/4 hp hoists, the hoist contactor is the same as the trolley contactor.

### Parts List for Electrical Parts, 2-Speed Hoist, 1-Speed Trolley

| Ref No. | Description                  | Part No. | Qty | Ref No. | Description                    | Part No. | Qty |
|---------|------------------------------|----------|-----|---------|--------------------------------|----------|-----|
| 1       | Gear Box Cover               | JM34     | 1   | 7       | End Clamp                      | 909J13   | 4   |
| 2       | Panel Plate                  | 257JM200 | 1   | 8       | Tie Cable Assembly             |          |     |
| 3       | Hoist Reversing Contactor*   |          |     | 9       | 3-Phase PB & Cable Assembly    | 955JG48  | 1   |
|         | 1/2 hp & 1/4 hp, 24V Coil    | 28860    | 1   | 9       | 115V Coil                      | —        | 1   |
|         | 1/2 hp & 1/4 hp, 115V Coil   | 24799    | 1   |         | (See Figures 22 - 24)          |          |     |
|         | 1 hp, 24V Coil               | 25943    | 1   | 10      | Panel Standoff                 | 200J4    | 3   |
|         | 1 hp, 115V Coil              | 24729    | 1   | 11      | 1/4" Internal-tooth Lockwasher | H4134    | 3   |
| 4       | Trolley Reversing Contactor* |          |     | 12      | 1/4-20UNC X 4" Screw           | H1027P   | 3   |
|         | 24V Coil                     | 28860    | 1   | 13      | 8-32UNC X 5/16" Screw          | H2751    | 2   |
|         | 115V Coil                    | 24799    | 1   | 14      | #8 External-tooth Lockwasher   | H4158    | 2   |
| 5       | Transformer*                 |          |     | 15      | 1/4" Flatwasher                | H4002P   | 1   |
|         | Pri.: 230/460V, Sec.: 24V    | 821J432  | 1   | 16      | 10-24UNC X 1/2" Screw          | H2970    | 2   |
|         | Pri.: 230/460V, Sec.: 115V   | 821J431  | 1   | 17      | Grommet                        | H9086    | 2   |
|         | Pri.: 575V, Sec.: 24V        | 821J452  | 1   |         |                                |          |     |
|         | Pri.: 575V, Sec.: 115V       | 821J451  | 1   |         |                                |          |     |
|         | Pri.: 208V, Sec.: 24V        | 821J472  | 1   |         |                                |          |     |
|         | Pri.: 208V, Sec.: 115V       | 821J471  | 1   |         |                                |          |     |
| 6       | Hoist Speed Control Relay    |          |     |         |                                |          |     |
|         | 1/2 hp & under, 24V Coil     | 28878    | 1   |         |                                |          |     |
|         | 1/2 hp & under, 115V Coil    | 28870    | 1   |         |                                |          |     |
|         | 1 hp, 24V Coil               | 28885    | 1   |         |                                |          |     |
|         | 1 hp, 115V Coil              | 28879    | 1   |         |                                |          |     |

**\* Coil voltage of the contactor and the secondary voltage of the transformer must be the same. This is referred to as the control voltage. Standard units are supplied with 24V Control.**

Contact your nearest Coffing Service Center for parts and service. For a complete list, see pages 50 and 51. Please have the hoist model number, serial number, and part number with description available for reference.

## Figure 21 - Electrical Parts 2-Speed Hoist, 2-Speed Trolley

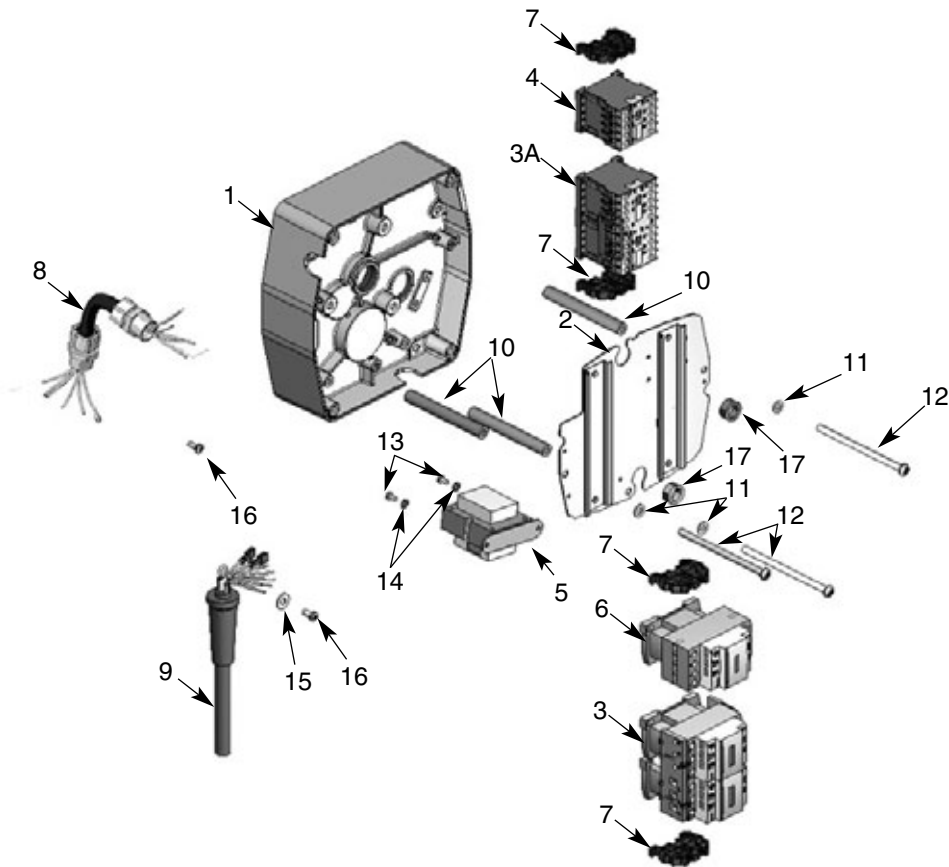

### Parts List for Electrical Parts, 2-Speed Hoist, 2-Speed Trolley

| Ref No. | Description                  | Part No. | Qty | Ref No. | Description                                  | Part No.  | Qty |
|---------|------------------------------|----------|-----|---------|--|-----------|-----|
| 1       | Gear Box Cover               | JM34     | 1   | 6       | Hoist Speed Control Relay                    |           |     |
| 2       | Panel Plate                  | 257JM200 | 1   |         | 1/2 hp & under, 24V Coil                     | 28878     | 1   |
| 3       | Hoist Reversing Contactor*   |          |     |         | 1/2 hp & under, 115V Coil                    | 28870     | 1   |
|         | 1/2 hp & 1/4 hp, 24V Coil    | 28860    | 1   |         | 1 hp, 24V Coil                               | 28885     | 1   |
|         | 1/2 hp & 1/4 hp, 115V Coil   | 24799    | 1   |         | 1 hp, 115V Coil                              | 28879     | 1   |
|         | 1 hp, 24V Coil               | 25943    | 1   | 7       | End Clamp                                    | 909J13    | 4   |
|         | 1 hp, 115V Coil              | 24729    | 1   | 8       | Tie Cable Assembly                           | 955JM48-2 | 1   |
| 3A      | Trolley Reversing Contactor* |          |     | 9       | PB & Cable Assembly<br>(See Figures 22 - 24) | —         | 1   |
|         | 24V Coil                     | 28860    | 1   | 10      | Panel Standoff                               | 200J4     | 3   |
|         | 115V Coil                    | 24799    | 1   | 11      | 1/4" Internal-tooth Lockwasher               | H4134     | 3   |
| 4       | Trolley Speed Control Relay* |          |     | 12      | 1/4-20UNC X 4" Screw                         | H1027P    | 3   |
|         | 24V Coil                     | 28878    | 1   | 13      | 8-32UNC X 5/16" Screw                        | H2751     | 2   |
|         | 115V Coil                    | 28870    | 1   | 14      | #8 External-tooth Lockwasher                 | H4158     | 2   |
| 5       | Transformer*                 |          |     | 15      | 1/4" Flatwasher                              | H4002P    | 1   |
|         | Pri.: 230/460V, Sec.: 24V    | 821J432  | 1   | 16      | 10-24UNC X 1/2" Screw                        | H2970     | 2   |
|         | Pri.: 230/460V, Sec.: 115V   | 821J431  | 1   | 17      | Grommet                                      | H9086     | 2   |
|         | Pri.: 575V, Sec.: 24V        | 821J452  | 1   |         |  |           |     |
|         | Pri.: 575V, Sec.: 115V       | 821J451  | 1   |         |  |           |     |
|         | Pri.: 208V, Sec.: 24V        | 821J472  | 1   |         |  |           |     |
|         | Pri.: 208V, Sec.: 115V       | 821J471  | 1   |         |  |           |     |

\* Coil voltage of the contactor and the secondary voltage of the transformer are the same. This is referred to as the control voltage. Standard units are supplied with 24V Control.

△ Not Shown.



Contact your nearest Coffing Service Center for parts and service. For a complete list, see pages 50 and 51. Please have the hoist model number, serial number, and part number with description available for reference.

## Figure 22 - Pushbutton Station 1-Speed Hoist, 1-Speed Trolley

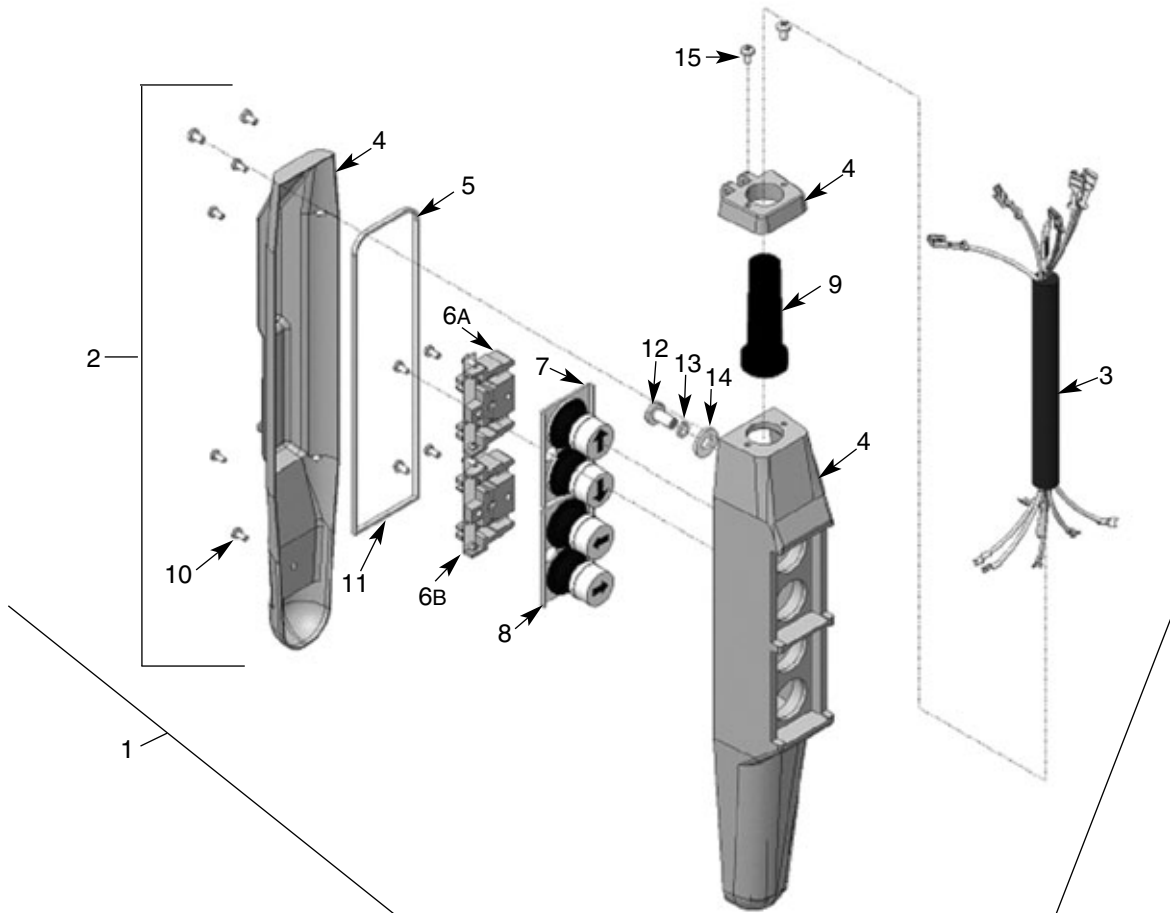

### Parts List for Pushbutton Station 1-Speed Hoist, 1-Speed Trolley

| Ref No. | Description                           | Part No.   | Qty | Ref No. | Description   | Part No. | Qty |
|---------|---------------------------------------|------------|-----|---------|---|----------|-----|
| 1       | Pushbutton Station and Cable Assembly |            |     | 6A      | Contact Assembly  |          |     |
|         | 10' Lift, 6' Cable Length             | PB4110-6   | 1   |         | (Includes item 7)   | 36987    | 1   |
|         | 15' Lift, 11' Cable Length            | PB4110-11  | 1   | 6B      | Contact Assembly  |          |     |
|         | 20' Lift, 16' Cable Length            | PB4110-16  | 1   |         | (Includes item 8)   | 70971    | 1   |
|         | Special (Specify Length)              | PB4110-S#  | 1   | 7       | Button Assembly (Hoist)   | 36988    | 1   |
| 2       | Pushbutton Assembly                   | 70954      | 1   | 8       | Button Assembly (Trolley)   | 36906    | 1   |
| 3       | Pushbutton Cable Assembly             |            |     | 9       | Grommet   | 70966    | 1   |
|         | 10' Lift, 6' Cable Length             | PBC4110-6  | 1   | *       | Hardware Kit  |          |     |
|         | 15' Lift, 11' Cable Length            | PBC4110-11 | 1   |         | (Includes Items 10-15)  | 70967    | 1   |
|         | 20' Lift, 16' Cable Length            | PBC4110-16 | 1   | △       | Warning Tag   | 687K3W   | 1   |
|         | Special (Specify Length)              | PBC4110-S# | 1   |         |   |          |     |
| 4       | Enclosure                             | 70961      | 1   | (#)     | <b>Equal to cable length in feet.</b>   |          |     |
| 5       | Gasket                                | 70963      | 1   |         | <b>Standard Lengths are 6', 11', 16', 18', 21' and 31'.</b>                               |          |     |
|         |                                       |            |     |         | <b>When ordering specify length, ie., PB4110-16 for pushbutton with 16' cable length.</b> |          |     |
|         |                                       |            |     | (△)     | <b>Not Shown</b>  |          |     |

Contact your nearest Coffing Service Center for parts and service. For a complete list, see pages 50 and 51. Please have the hoist model number, serial number, and part number with description available for reference.

## Figure 23A - Pushbutton Station 2-Speed Hoist, 1-Speed Trolley

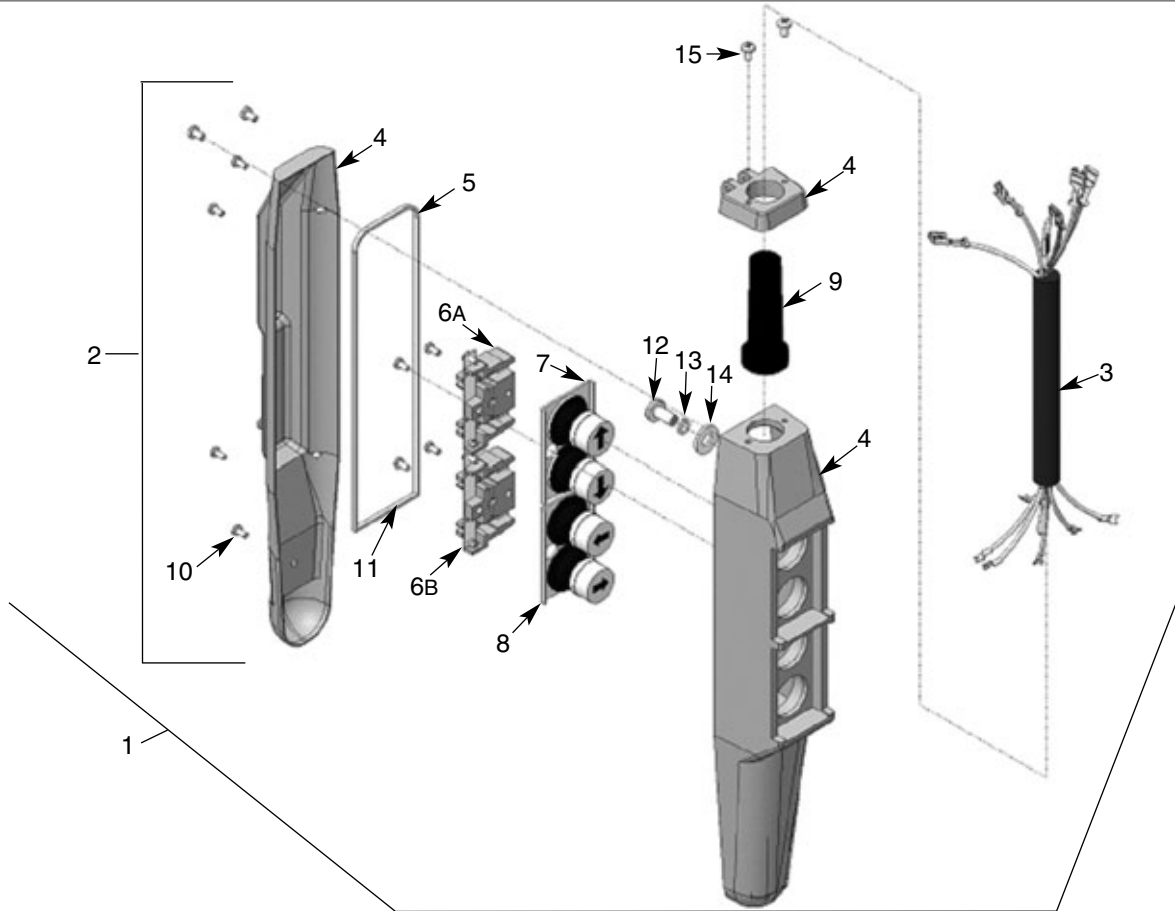

### Parts List for Pushbutton Station 2-Speed, 1-Speed

| Ref No. | Description                           | Part No.   | Qty | Ref No. | Description                       | Part No. | Qty |
|---------|---------------------------------------|------------|-----|---------|-----------------------------------|----------|-----|
| 1       | Pushbutton Station and Cable Assembly |            |     | 6B      | Trolley Contact Assembly, 1-Speed |          |     |
|         | 10' Lift, 6' Cable Length             | PB4210-6   | 1   |         | (Includes item 8)                 | 70971    | 1   |
|         | 15' Lift, 11' Cable Length            | PB4210-11  | 1   | 7       | Hoist Button Assembly,            |          |     |
|         | 20' Lift, 16' Cable Length            | PB4210-16  | 1   |         | 2-Speed                           | 36869    | 1   |
|         | Special (Specify Length)              | PB4210-S#  | 1   | 8       | Trolley Button Assembly,          |          |     |
| 2       | Pushbutton Assembly                   | 70953      | 1   |         | 1-Speed                           | 36906    | 1   |
| 3       | Pushbutton Cable Assembly             |            |     | 9       | Grommet                           | 70966    | 1   |
|         | 10' Lift, 6' Cable Length             | PBC4210-6  | 1   | *       | Hardware Kit                      |          |     |
|         | 15' Lift, 11' Cable Length            | PBC4210-11 | 1   |         | (Includes Items 10-15)            | 70967    | 1   |
|         | 20' Lift, 16' Cable Length            | PBC4210-16 | 1   | Δ       | Warning Tag                       | 687K3W   | 1   |
|         | Special (Specify Length)              | PBC4210-S# | 1   |         |                                   |          |     |
| 4       | Enclosure                             | 70961      | 1   |         |                                   |          |     |
| 5       | Gasket                                | 70963      | 1   |         |                                   |          |     |
| 6A      | Hoist Contact Assembly, 2-Speed       |            |     |         |                                   |          |     |
|         | (Includes item 7)                     | 70964      | 1   |         |                                   |          |     |

(#) Equal to cable length in feet.  
**Standard Lengths are 6', 11', 16', 18', 21' and 31'.**  
**When ordering specify length, ie., PB4210-16 for pushbutton with 16' cable length.**  
(Δ) Not Shown

Contact your nearest Coffing Service Center for parts and service. For a complete list, see pages 50 and 51. Please have the hoist model number, serial number, and part number with description available for reference.

## Figure 23B - Pushbutton Station 1-Speed Hoist, 2-Speed Trolley

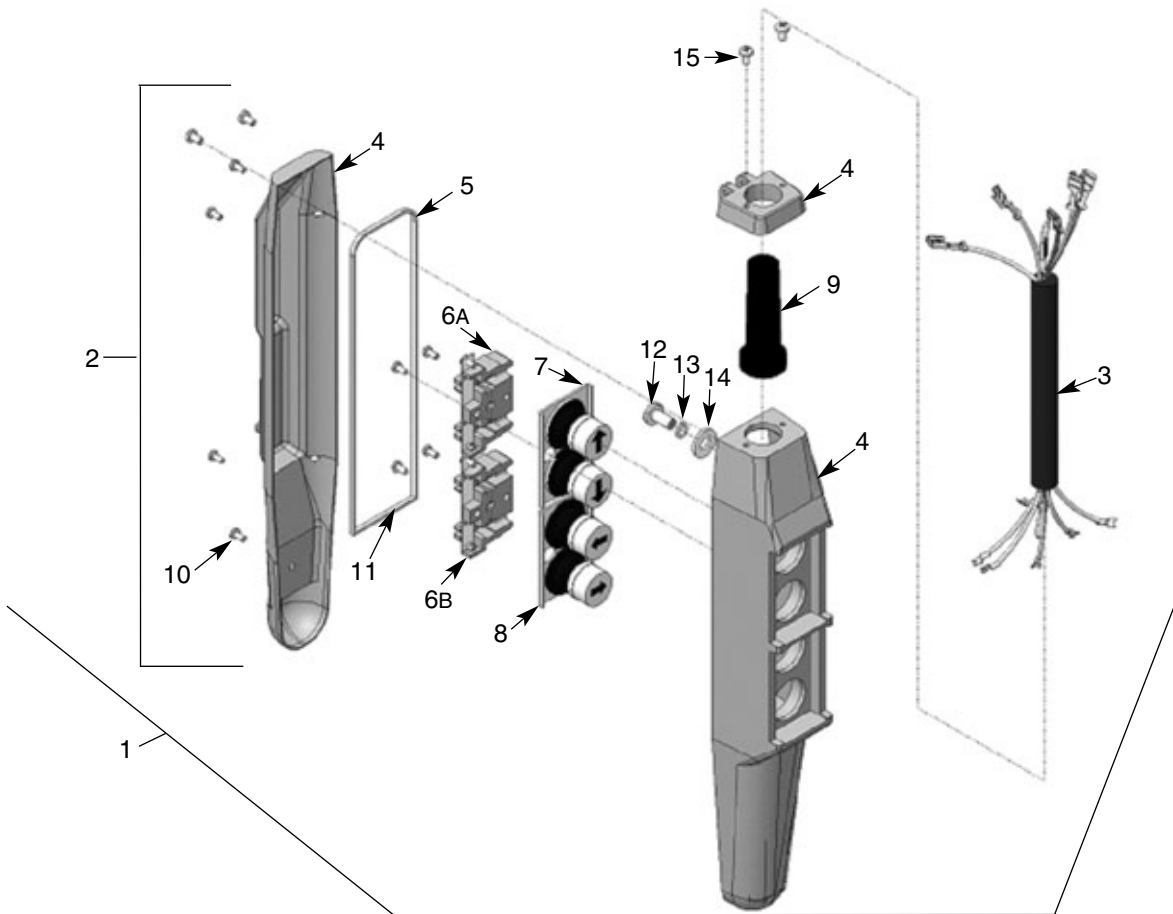

### Parts List for Pushbutton Station 1-Speed, 2-Speed

| Ref No. | Description                           | Part No.   | Qty | Ref No. | Description                       | Part No. | Qty |
|---------|---------------------------------------|------------|-----|---------|-----------------------------------|----------|-----|
| 1       | Pushbutton Station and Cable Assembly |            |     | 6B      | Trolley Contact Assembly, 2-Speed |          |     |
|         | 10' Lift, 6' Cable Length             | PB4120-6   | 1   |         | (Includes item 8)                 | 70972    | 1   |
|         | 15' Lift, 11' Cable Length            | PB4120-11  | 1   | 7       | Hoist Button Assembly,            |          |     |
|         | 20' Lift, 16' Cable Length            | PB4120-16  | 1   |         | 1-Speed                           | 36988    | 1   |
|         | Special (Specify Length)              | PB4120-S#  | 1   | 8       | Trolley Button Assembly,          |          |     |
| 2       | Pushbutton Assembly                   | 70955      | 1   |         | 2-Speed                           | 70959    | 1   |
| 3       | Pushbutton Cable Assembly             |            |     | 9       | Grommet                           | 70966    | 1   |
|         | 10' Lift, 6' Cable Length             | PBC4120-6  | 1   | *       | Hardware Kit                      |          |     |
|         | 15' Lift, 11' Cable Length            | PBC4120-11 | 1   |         | (Includes Items 10-15)            | 70967    | 1   |
|         | 20' Lift, 16' Cable Length            | PBC4120-16 | 1   | △       | Warning Tag                       | 687K3W   | 1   |
|         | Special (Specify Length)              | PBC4120-S# | 1   |         |                                   |          |     |
| 4       | Enclosure                             | 70961      | 1   |         |                                   |          |     |
| 5       | Gasket                                | 70963      | 1   |         |                                   |          |     |
| 6A      | Hoist Contact Assembly, 1-Speed       |            |     |         |                                   |          |     |
|         | (Includes item 7)                     | 36987      | 1   |         |                                   |          |     |

(#) Equal to cable length in feet.  
Standard Lengths are 6', 11', 16', 18', 21' and 31'.  
When ordering specify length, ie., PB4120-16 for pushbutton with 16' cable length.  
(△) Not Shown

Contact your nearest Coifing Service Center for parts and service. For a complete list, see pages 50 and 51. Please have the hoist model number, serial number, and part number with description available for reference.

## Figure 24 - Pushbutton Station 2-Speed Hoist, 2-Speed Trolley

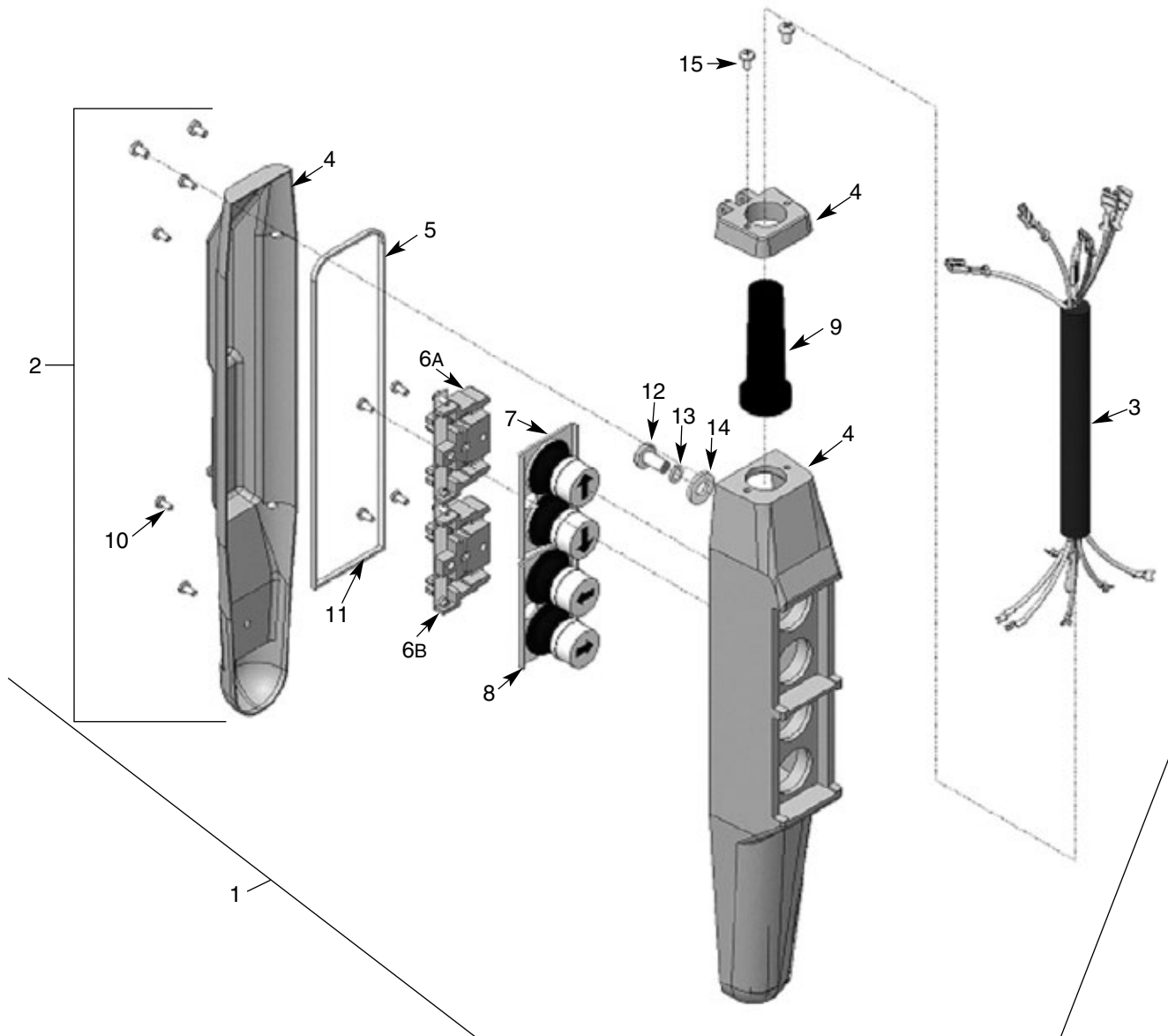

Contact your nearest Coffing Service Center for parts and service. For a complete list, see pages 50 and 51. Please have the hoist model number, serial number, and part number with description available for reference.

**Parts List for Pushbutton Station 2-Speed Hoist, 2-Speed Trolley**

| Ref. No. | Description                           | Part No.   | Qty |
|----------|---------------------------------------|------------|-----|
| 1        | Pushbutton Station and Cable Assembly |            |     |
|          | 10' Lift, 6' Cable Length             | PB4220-6   | 1   |
|          | 15' Lift, 11' Cable Length            | PB4220-11  | 1   |
|          | 20' Lift, 16' Cable Length            | PB4220-16  | 1   |
|          | Special (Specify Length)              | PB4220-S#  | 1   |
| 2        | Pushbutton Assembly                   | 70958      | 1   |
| 3        | Pushbutton Cable Assembly             |            |     |
|          | 10' Lift, 6' Cable Length             | PBC4220-6  | 1   |
|          | 15' Lift, 11' Cable Length            | PBC4220-11 | 1   |
|          | 20' Lift, 16' Cable Length            | PBC4220-16 | 1   |
|          | Special (Specify Length)              | PBC4220-S# | 1   |
| 4        | Enclosure                             | 70961      | 1   |
| 5        | Gasket                                | 70963      | 1   |
| 6A       | Contact Assembly (Hoist)              | 70964      | 1   |
|          | (Includes Item 7)                     |            |     |
| 6B       | Contact Assembly (Trolley)            | 70972      | 1   |
|          | (Includes Item 8)                     |            |     |
| 7        | Button Assembly 2-Speed (Hoist)       | 36869      | 1   |
| 8        | Button Assembly 2-Speed (Trolley)     | 70959      | 1   |
| 9        | Grommet                               | 70966      | 1   |
| *        | Hardware Kit                          | 70967      | 1   |
|          | (Includes Items 10-15)                |            |     |
| △        | Warning Tag                           | 687K3W     | 1   |

(#) **Equal to cable length in feet. Standard Lengths are 6', 11', 16', 18', 21' and 31'. When ordering specify length, ie., PB4220-16 for pushbutton with 16' cable length.**

(△) **Not Shown**

Contact your nearest Coffing Service Center for parts and service. For a complete list, see pages 50 and 51. Please have the hoist model number, serial number, and part number with description available for reference.

## Figure 25 - Standard Limit Switch Assembly

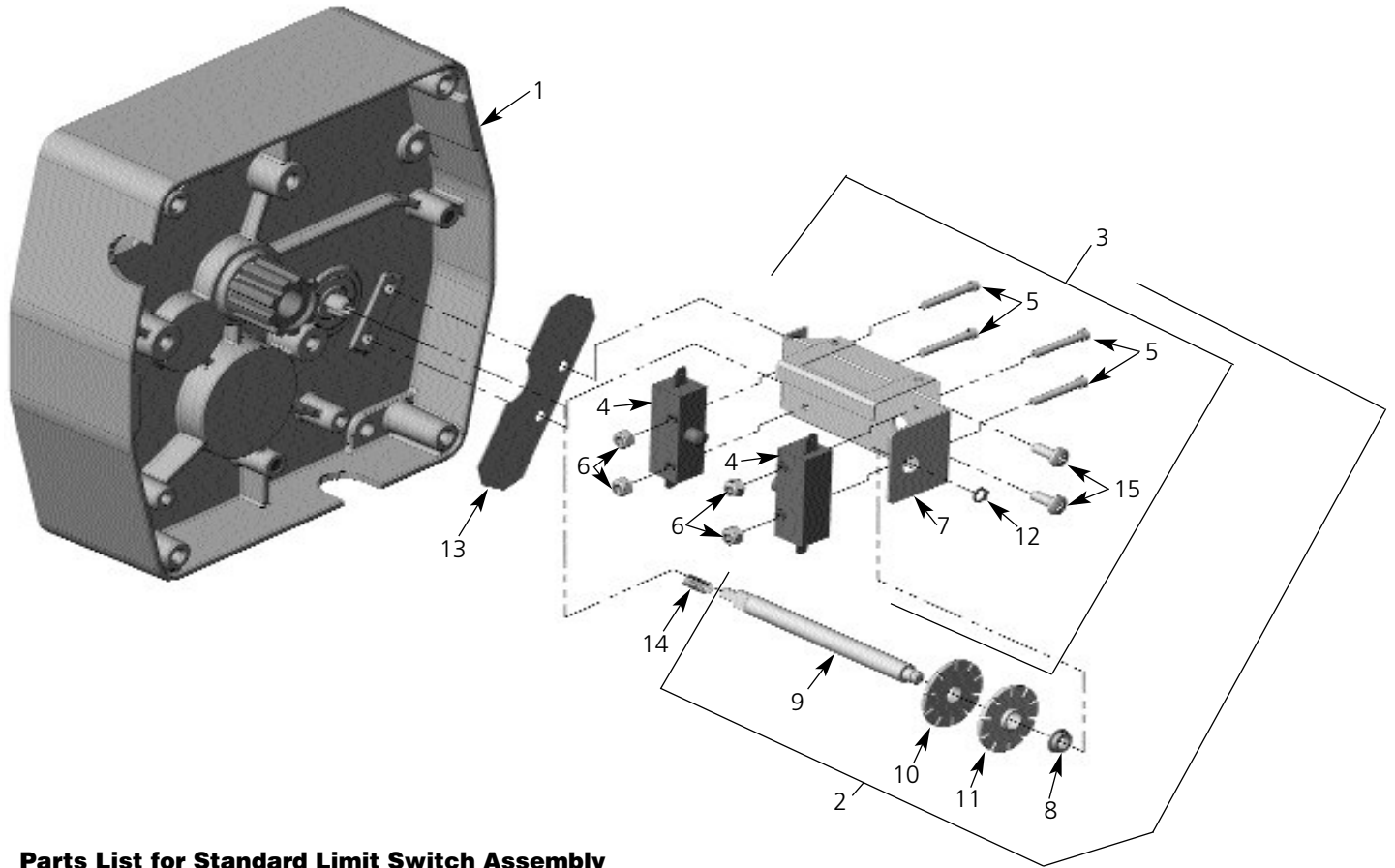

### Parts List for Standard Limit Switch Assembly

| Ref No. | Description   | Part No. | Qty | Ref No. | Description               | Part No.   | Qty |
|---------|---|----------|-----|---------|---------------------------|------------|-----|
| 1       | Transmission Cover                                    | JM34     | 1   | 8       | Bushing                   | JF531-4    | 1   |
| 2       | Limit Switch Assembly<br>(Includes Items 4-12)        | 918JG4   | 1   | 9       | Limit Switch Shaft        | JF117-3S   | 1   |
| 3       | Limit Switch Bracket Assembly<br>(Includes Items 4-8) | 918JG3   | 1   | 10      | Limit Switch Nut (silver) | SK6000-63Z | 1   |
| 4       | Switch  | 815J1    | 2   | 11      | Limit Switch Nut (gold)   | SK6000-63W | 1   |
| 5       | 6-32UNC X 1" Screw                                    | H1402P   | 4   | 12      | Retaining Ring            | H5520      | 1   |
| 6       | 6-32UNC Elastic Locknut                               | H3944    | 4   | 13      | Insulator                 | JM754      | 1   |
| 7       | Limit Switch Bracket<br>(Includes Item 8)             | JF900-3  | 1   | 14      | Spring                    | JF343-3    | 1   |
|         |   |          |     | 15      | 10-24UNC X 1/2" Screw     | H2970      | 2   |

Contact your nearest Coffing Service Center for parts and service. For a complete list, see pages 50 and 51. Please have the hoist model number, serial number, and part number with description available for reference.

## Figure 26 - Long Lift Limit Switch Assembly

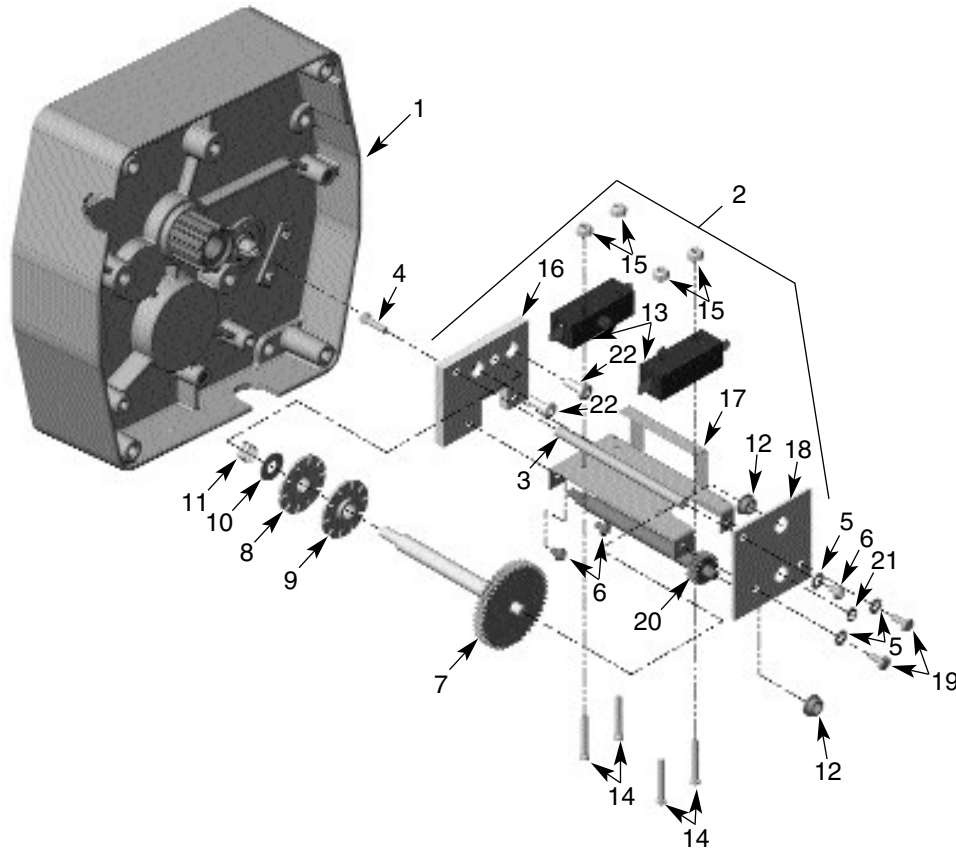

### Parts List for Long Lift Limit Switch Assembly

| Ref No. | Description                                    | Part No.   | Qty | Ref No. | Description              | Part No. | Qty |
|---------|--|------------|-----|---------|--------------------------|----------|-----|
| 1       | Transmission Cover                             | JM34       | 1   | 13      | Switch                   | 815J1    | 2   |
| 2       | Limit Switch Assembly<br>(Includes Items 3-21) | 944JG6     | 1   | 14      | 6-32UNC X 1" Screw       | H1402P   | 4   |
| 3       | Post   | 110J14     | 1   | 15      | 6-32UNC Elastic Locknut  | H3944    | 4   |
| 4       | 8-32UNC X 1/2" Screw                           | H1210      | 1   | 16      | Mounting Plate           | 129J1    | 1   |
| 5       | #8 External-tooth Lockwasher                   | H4158      | 3   | 17      | Frame and Guide Assembly | 258JG7   | 1   |
| 6       | 8-32UNC X 1/4" Screw                           | 854823     | 3   | 18      | End Plate                | 258J8    | 1   |
| 7       | Limit Switch Shaft & Gear                      | 117JG2     | 1   | 19      | 8-32UNC X 3/8" Screw     | H2741P   | 2   |
| 8       | Limit Switch Nut (gold)                        | SK6000-63W | 1   | 20      | Drive Pinion             | 427J1    | 1   |
| 9       | Limit Switch Nut (silver)                      | SK6000-63Z | 1   | 21      | Retaining Ring           | H5520    | 1   |
| 10      | Thrust Washer                                  | 255K16     | 1   | 22      | 10-24UNC X 3/8" Screw    | H2981P   | 2   |
| 11      | Spring   | PB287      | 1   |         |                          |          |     |
| 12      | Bushing  | JF531-4    | 2   |         |                          |          |     |

Contact your nearest Coffing Service Center for parts and service. For a complete list, see pages 50 and 51. Please have the hoist model number, serial number, and part number with description available for reference.

## Figure 27 - Gearbox

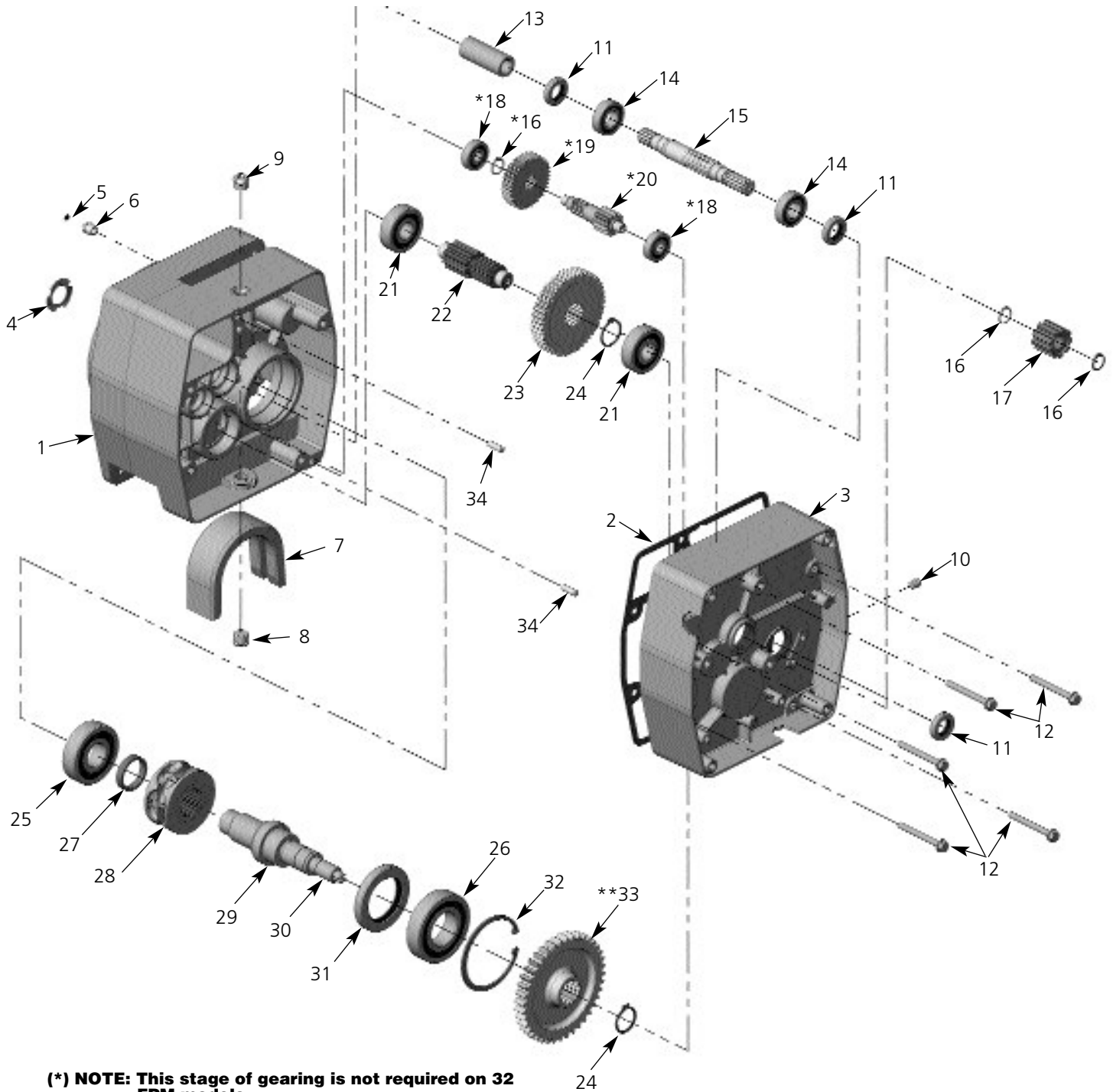

**(\*) NOTE: This stage of gearing is not required on 32 FPM models.**

**(\*\*) NOTE: Orient the output gear (33) with long boss towards the transmission cover (3).**



Contact your nearest Coffing Service Center for parts and service. For a complete list, see pages 50 and 51. Please have the hoist model number, serial number, and part number with description available for reference.

## Parts List for Gearbox

| Ref. No. | Description                                  | Part No.   | Qty      |
|----------|--|------------|----------|
| 1        | Sheave Housing                               | JM3533     | 1        |
| 2        | Transmission Gasket                          | JM560      | 1        |
| 3        | Transmission Cover<br>(Includes Oil Seals)   | JM34       | 1        |
| 4        | Spring Washer                                | 360J1      | 1        |
| 5        | O-ring                                       | H5605      | 1        |
| 6        | Pressure Relief Fitting                      | SK1912-21W | 1        |
| 7        | Chain Guide                                  | JM273      | 1        |
| 8        | Oil Plug - Drain                             | H6297      | 1        |
| 9        | Oil Plug - Fill                              | H6296      | 1        |
| 10       | Oil Plug - Level                             | H6295      | 1        |
| 11       | Oil Seal                                     | 561K2      | 3        |
| 12       | Screw, HWH Self-threading                    | H2693P     | 5        |
| 13       | Motor Coupling                               | JM107      | 1        |
| 14       | Bearing                                      | 500K33     | 2        |
| 15       | Input Pinion<br>8 & 16 fpm                   | JL400B     | 1        |
|          | 32 fpm                                       | JL400-1    | 1        |
| 16       | Retaining Ring                               | H5501      | 3        |
| 17       | Brake Adapter                                | JM142      | 1        |
| 18       | Bearing for 8 & 16 fpm                       | 500K34     | 2        |
| 19       | High Speed Pinion for 8 & 16 fpm             | JL426      | 1        |
| 20       | Intermediate Pinion<br>1/4 & 1/2 ton, 16 fpm | JL402A     | 1        |
|          | 1 & 2 ton                                    | JL403A     | 1        |
| 21       | Bearing                                      | 500K39     | 2        |
| 22       | Output Pinion                                | JL401      | 1        |
| 23       | Overload Clutch Assembly<br>1/8 ton, 32 fpm  | 591JG22    | 1        |
|          | 1/4 ton, 16 fpm                              | 591JG25    | 1        |
|          | 1/4 ton, 32 fpm                              | 591JG22    | 1        |
|          | 1/2 ton, 16 fpm                              | 591JG16    | 1        |
|          | 1/2 ton, 32 fpm                              | 591JG21    | 1        |
|          | 1 & 2 ton                                    | 591JG17    | 1        |
| 24       | Retaining Ring                               | H5503      | 2        |
| 25       | Bearing                                      | 500K28     | 1        |
| 26       | Bearing                                      | P003255    | 1        |
| 27       | Spacer - Load Sheave                         | JM127      | 1        |
| 28       | Load Sheave-9/32" Chain                      | JF16-3     | 1        |
| 29       | Load Sheave Shaft                            | JM132      | 1        |
| 30       | Stub Shaft - Limit Switch Drive              | JM140      | 1        |
| 31       | Oil Seal                                     | 011612800  | 1        |
| 32       | Retaining Ring                               | H5598      | 1        |
| 33       | Output Gear                                  | JL421      | 1        |
| 34       | Dowel Pin                                    | H5382      | 2        |
| *        | Gear Oil                                     | H7642      | 1½<br>pt |

\* Not Shown

Contact your nearest Coffing Service Center for parts and service. For a complete list, see pages 50 and 51. Please have the hoist model number, serial number, and part number with description available for reference.

## Figure 28 - Chaining Parts

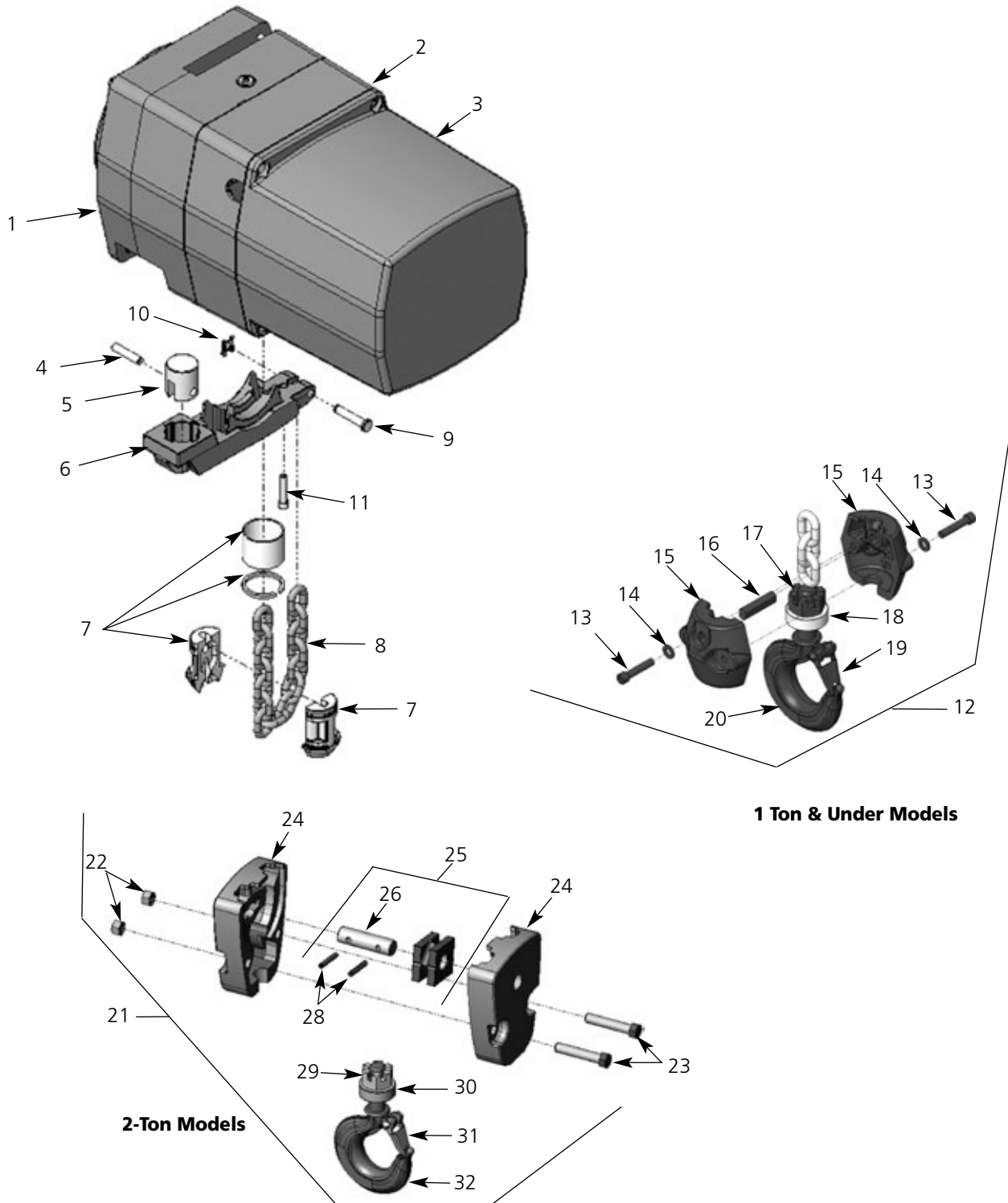

Contact your nearest Coffing Service Center for parts and service. For a complete list, see pages 50 and 51. Please have the hoist model number, serial number, and part number with description available for reference.

### Parts List for Chaining Parts

| Ref No. | Description                                      | Part No. | Qty | Ref No. | Description               | Part No. | Qty |
|---------|--|----------|-----|---------|---------------------------|----------|-----|
| 1       | Housing  | JM3533   | 1   | 23      | Load Block Screw          | H2403P   | 2   |
| 2       | Transmission Cover                               | JM34     | 1   | 24      | Load Block Frame          | JF30-1   | 2   |
| 3       | Electrical Cover                                 | JM36     | 1   | 25      | Sheave Shaft Assembly     | JF917-1  | 1   |
| 4       | Anchor Pin (2 Ton Only)                          | JM111    | 1   | 26      | Sheave Shaft              | JF122-1  | 1   |
| 5       | Anchor (2 Ton Only)                              | JM109    | 1   | 27      | Sheave & Bearing Assembly | JF916    | 1   |
| 6       | Chain Stripper                                   | JM254    | 1   | 28      | Roll Pin                  | H5234    | 2   |
| 7       | Chain Stop Kit                                   | 75JG6K   | 1   | 29      | 3/8-24 Hex Locknut        | H3991P   | 1   |
|         | (Kits include halves, sleeve and retaining ring) |          |     | 30      | Bearing                   | JF511    | 1   |
| 8       | Load Chain                                       | JL19-1   | •   | 31      | Latch Kit                 | 4X1305   | 1   |
| 9       | Attachment Pin                                   | JM18-1   | 1   | 32      | Bottom Hook Assembly      |          |     |
| 10      | Retaining Clip                                   | H5597    | 1   |         | with Latch for 2 Ton      | 3KG1W    | 1   |
| 11      | 1/4-20UNC x 1 1/4"                               |          |     |         |                           |          |     |
|         | Socket Head Cap Screw                            | S49-77   | 1   |         |                           |          |     |
| 12      | Bottom Block Assembly                            |          |     |         |                           |          |     |
|         | 1 ton & Under                                    | 913JG3AS | 1   |         |                           |          |     |
| 13      | 1/4-20UNC x 1 1/4"                               | S49-77   | 2   |         |                           |          |     |
|         | Socket Head Cap Screw                            |          |     |         |                           |          |     |
| 14      | 1/4" Internal-tooth                              |          |     |         |                           |          |     |
|         | Lockwasher                                       | H4134    | 2   |         |                           |          |     |
| 15      | Load Block Frame                                 | 30J14    | 2   |         |                           |          |     |
| 16      | Load Block Pin                                   | 18J8     | 1   |         |                           |          |     |
| 17      | Slotted Hex Nut                                  | H3986P   | 1   |         |                           |          |     |
| 18      | Bearing  | JF510    | 1   |         |                           |          |     |
| 19      | Latch Kit  | 4X1304   | 1   |         |                           |          |     |
| 20      | Bottom Hook Assembly                             |          |     |         |                           |          |     |
|         | with Latch for 1 Ton & Under                     | 3JG20S   | 1   |         |                           |          |     |
| 21      | Bottom Block Assembly                            |          |     |         |                           |          |     |
|         | 2 Ton  | JF914-6  | 1   |         |                           |          |     |
| 22      | 3/8-24 Hex Locknut                               | H3964P   | 2   |         |                           |          |     |

**\* Replacement chain is sold by the foot. For single-chained models, add 2 ft to the lift for the total amount of feet. For double-chained models, double the lift and add 3 ft.**

Contact your nearest Coffing Service Center for parts and service. For a complete list, see pages 50 and 51. Please have the hoist model number, serial number, and part number with description available for reference.

## Figure 29 - Standard Trolley General Assembly

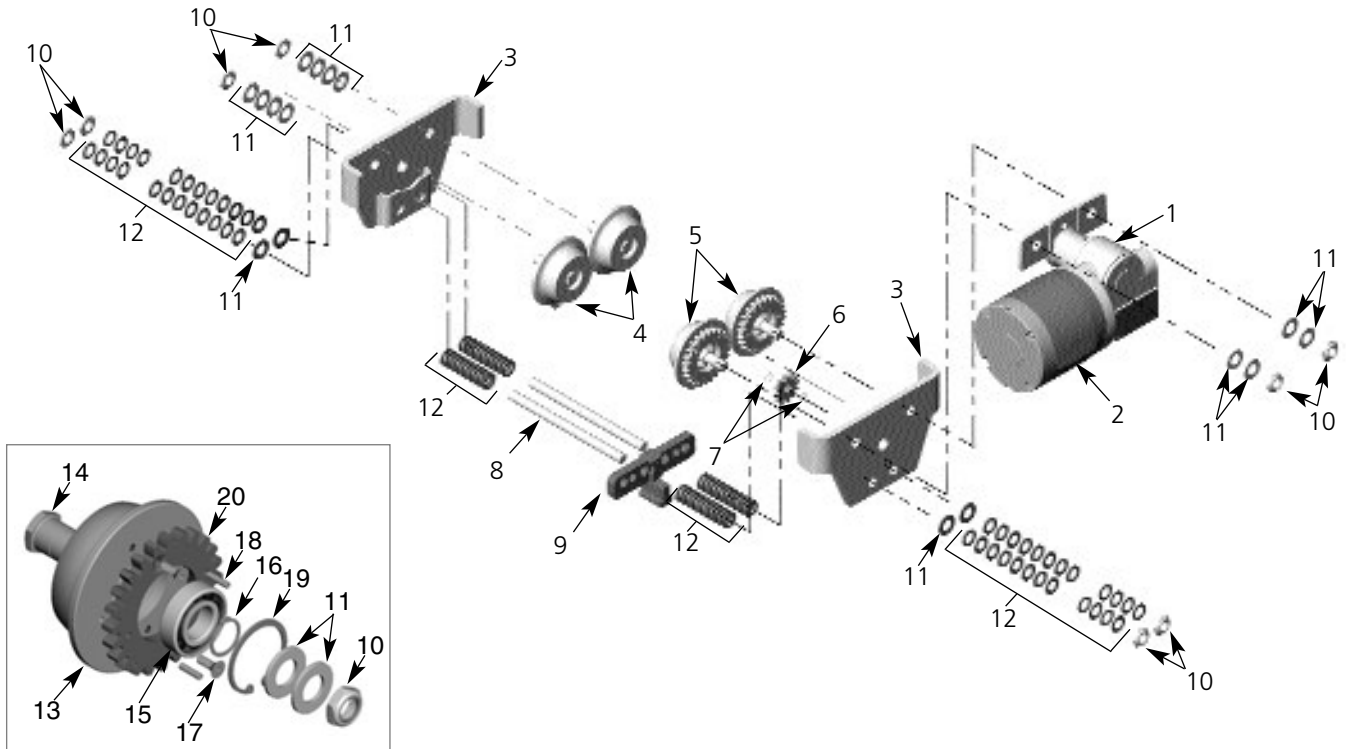

### Parts List for Standard Trolley General Assembly

| Ref No. | Description  | Part No. | Qty | Ref No. | Description                     | Part No.  | Qty |
|---------|--|----------|-----|---------|---------------------------------|-----------|-----|
| 1       | Trolley Transmission Assembly<br>(See Figures 30 - 31) | —        | 1   | 11      | 13/16" Flatwasher (.125" thick) | H4211     | 16  |
| 2       | Motor, 1/4 hp, 230/460V<br>(See Figures 32 - 33)       | —        | 1   | 12      | 3/4" Flatwasher (.075" thick)   | H4210     | #   |
| 3       | Side Plate   | 5K101    | 2   |         | 3/4" Flatwasher (.135" thick)   | H4209     | #   |
| 4       | Plain Wheel Assembly                                   | 45JG1PH  | 2   | 13      | Wheel                           | 45J1G     | 1   |
| 5       | Geared Wheel Assembly                                  | 45JG1G-1 | 2   | 14      | Wheel Axle                      | 102K11    | 1   |
| 6       | Output Pinion  | 420K1    | 1   | 15      | Bearing                         | JF504-2   | 1   |
| 7       | Retaining Ring   | H5501    | 2   | 16      | Retaining Ring                  | H5549     | 1   |
| 8       | Load Pin   | 103K30-2 | 2   | 17      | Screw                           | H2165     | 2   |
| 9       | Suspension Lug Assembly                                | JM50C    | 1   | 18      | Spring Pin 3/16 x 3/4           | H5331     | 2   |
| 10      | 3/4-16UNF Elastic Stop Nut                             | H3945    | 8   | 19      | Retaining Ring                  | SK2658-6W | 1   |
|         |  |          |     | 20      | Gear                            | 420K2     | 1   |

(#) See Figure 3, page 6 for quantities and locations.

Contact your nearest Coffing Service Center for parts and service. For a complete list, see pages 50 and 51. Please have the hoist model number, serial number, and part number with description available for reference.

## Figure 30 - Trolley Transmission

**Standard Transmissions:**  
**930JMC1R, 35, 24 & 18 fpm**  
**930JMC2R, 75 & 50 FPM**  
**930JMC3R, 100 FPM**  
**930JMC4R, 150 FPM**

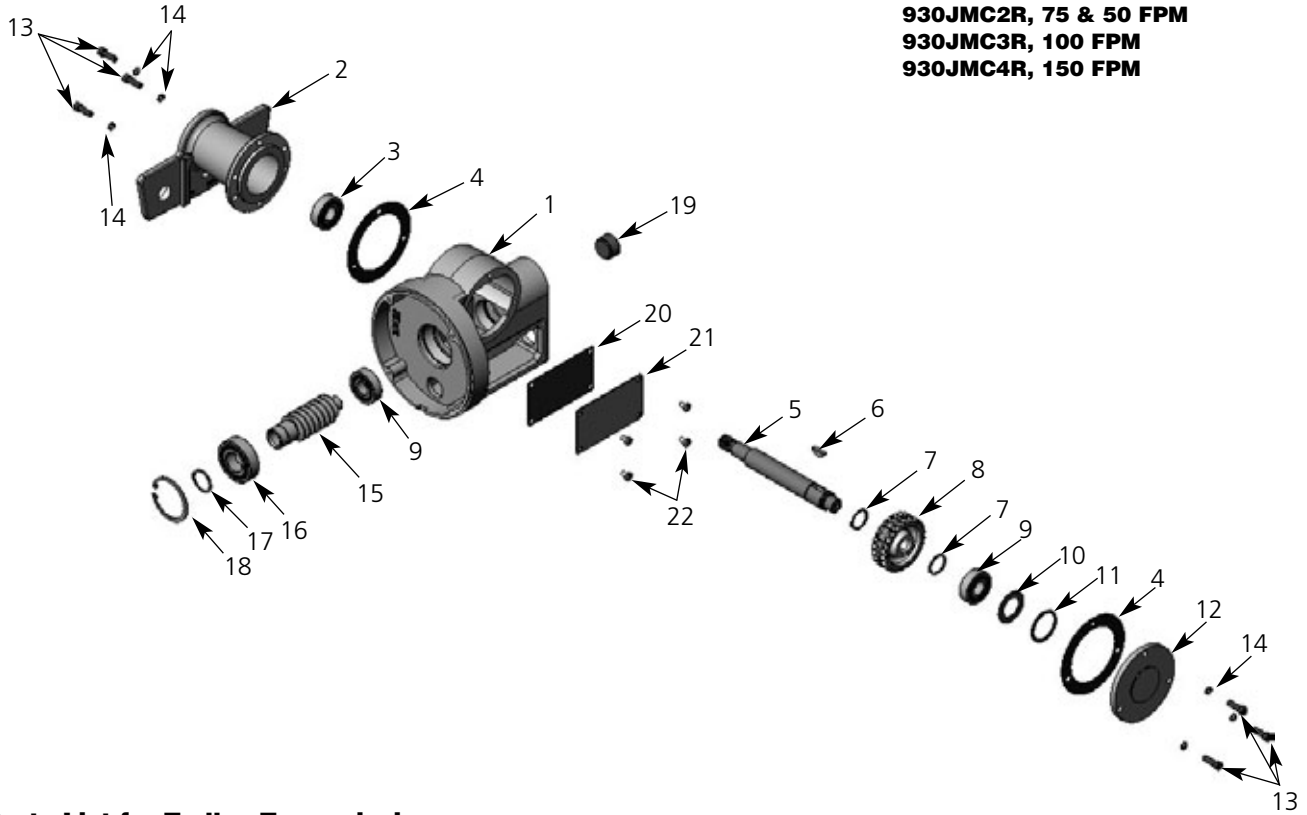

### Parts List for Trolley Transmission

| Ref No. | Description             | Part No. | Qty | Ref No. | Description                         | Part No.  | Qty |
|---------|-------------------------|----------|-----|---------|-------------------------------------|-----------|-----|
| 1       | Gear Housing            | 39K22    | 1   | 13      | 1/4-20UNC x 3/4" Socket Head Screw  | H2215     | 6   |
| 2       | Housing Adapter         | 38K60B   | 1   | 14      | 1/4" Spring Lockwasher              | H4084P    | 3   |
| 3       | Bearing                 | 500K3    | 1   | 15      | Worm                                |           |     |
| 4       | Gasket                  | 560K2    | 2   |         | 35, 24 & 18 FPM                     | 485K21    | 1   |
| 5       | Output Shaft            | 100K21   | 1   |         | 75 & 50 FPM                         | 485K22    | 1   |
| 6       | Woodruff Key            | S23-15   | 1   |         | 100 FPM                             | 485K23    | 1   |
| 7       | External Retaining Ring | H5527    | 2   |         | 150 FPM                             | 485K24    | 1   |
| 8       | Worm Gear               |          |     | 16      | Bearing                             | JF504-2   | 1   |
|         | 35, 24 & 18 FPM         | 487K4    | 1   | 17      | External Retaining Ring             | H5549     | 1   |
|         | 75 & 50 FPM             | 487K3    | 1   | 18      | Internal Retaining Ring             | SK2658-6W | 1   |
|         | 100 FPM                 | 487K2    | 1   | 19      | Plug                                | S25-13    | 1   |
|         | 150 FPM                 | 487K1    | 1   | 20      | Gasket                              | 560K3     | 2   |
| 9       | Bearing                 | 500K7    | 2   | 21      | Splice Plate                        | 295K1     | 2   |
| 10      | Shim Washer             | 202K1    | 1   | 22      | #10-24UNC x 3/8" Slotted Head Screw | H1009P    | 8   |
| 11      | O-ring                  | H5609    | 1   |         |                                     |           |     |
| 12      | End cap                 | 32K3     | 1   |         |                                     |           |     |

Contact your nearest Coffing Service Center for parts and service. For a complete list, see pages 50 and 51. Please have the hoist model number, serial number, and part number with description available for reference.

## Figure 31 - Trolley Transmission with Optional Brake

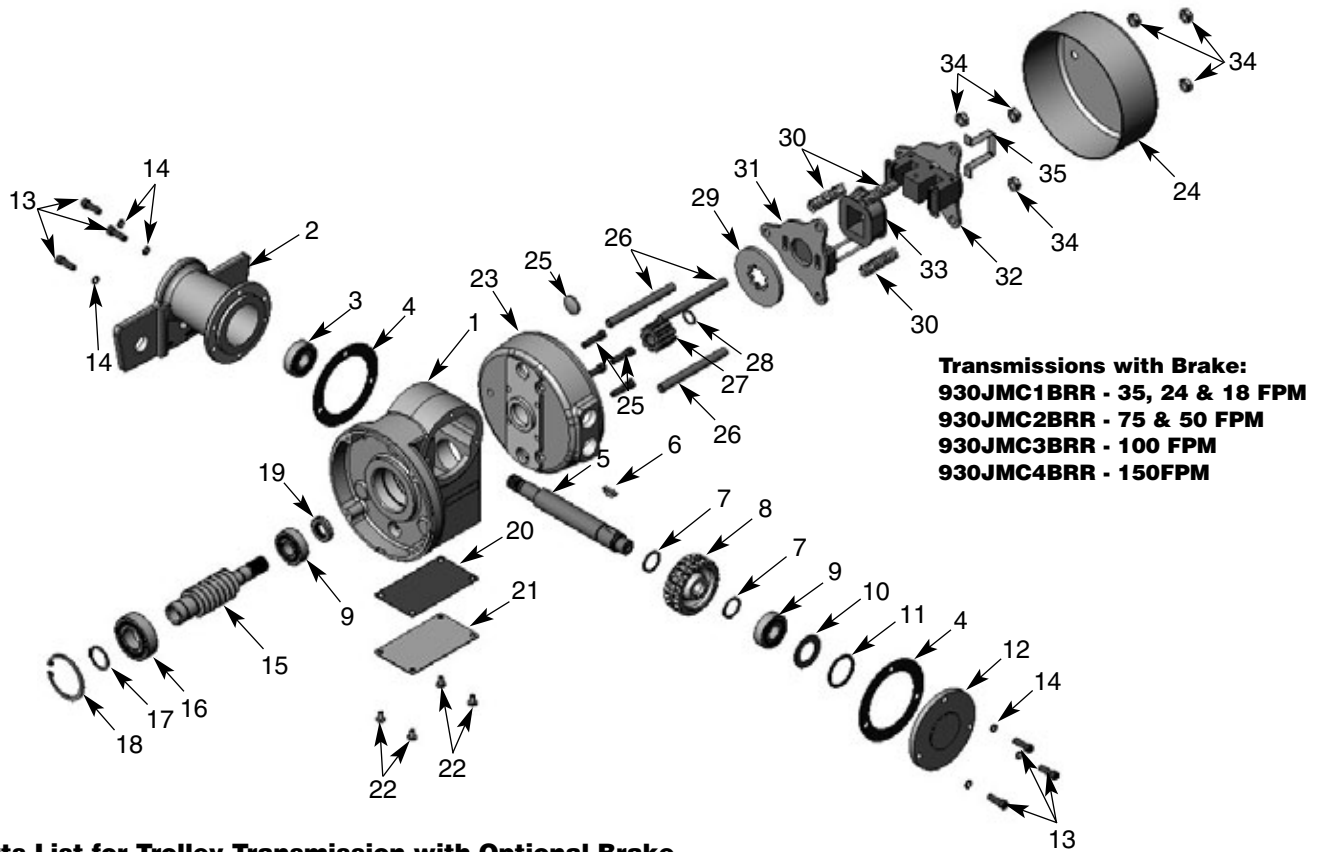

### Parts List for Trolley Transmission with Optional Brake

| Ref No. | Description                        | Part No. | Qty | Ref No. | Description                        | Part No.  | Qty |
|---------|------------------------------------|----------|-----|---------|------------------------------------|-----------|-----|
| 1       | Gear Housing                       | 39K23    | 1   | 18      | Internal Retaining Ring            | SK2658-6W | 1   |
| 2       | Housing Adapter                    | 38K60B   | 1   | 19      | Oil Seal                           | 561K2     | 1   |
| 3       | Bearing                            | 500K3    | 1   | 20      | Gasket                             | 560K3     | 2   |
| 4       | Gasket                             | 560K2    | 2   | 21      | Splice Plate                       | 295K1     | 2   |
| 5       | Output Shaft                       | 100K12   | 1   | 22      | #10-24NC x 3/8" Slotted Head Screw | H1009P    | 8   |
| 6       | Woodruff Key                       | S23-15   | 1   | 23      | Brake Housing                      | 37J11     | 1   |
| 7       | External Retaining Ring            | H5527    | 2   | 24      | Brake Cover                        | 36J10     | 1   |
| 8       | Worm Gear                          |          |     | 25      | Socket Head Screw                  | S49-12    | 4   |
|         | 35, 24 & 18 FPM                    | 487K4    | 1   | 26      | Stud                               | 141J12    | 3   |
|         | 75 & 50 FPM                        | 487K3    | 1   | 27      | Brake Adapter                      | JL142     | 1   |
|         | 100 FPM                            | 487K2    | 1   | 28      | Retaining Ring                     | H5501     | 1   |
|         | 150 FPM                            | 487K1    | 1   | 29      | Brake Disc                         | 581J1A    | 1   |
| 9       | Bearing                            | 500K7    | 2   | 30      | Spring                             | 344J6     | 3   |
| 10      | Shim Washer                        | 202K1    | 1   | 31      | Plate & Armature                   | JF858     | 1   |
| 11      | O-ring                             | H5609    | 1   | 32      | Plate & "E" Frame                  | JF857     | 1   |
| 12      | End Cap                            | 32K3     | 1   | 33      | Brake Coil                         |           |     |
| 13      | 1/4-20UNC x 3/4" Socket Head Screw | H2215    | 6   |         | 115V                               | JF853-1   | 1   |
| 14      | 1/4" Spring Lockwasher             | H4084P   | 3   |         | 230V                               | JF853-2   | 1   |
| 15      | Worm                               |          |     |         | 460V                               | JF853-3   | 1   |
|         | 35, 24 & 18 FPM                    | 485K25   | 1   |         | 575V                               | JF853-4   | 1   |
|         | 75 & 50 FPM                        | 485K26   | 1   |         | 208V                               | JF853-5   | 1   |
|         | 100 FPM                            | 485K27   | 1   | 34      | Nut                                | H3978     | 3   |
|         | 150 FPM                            | 485K28   | 1   | 35      | Retainer                           | JF710     | 1   |
| 16      | Bearing                            | JF504-2  | 1   |         |                                    |           |     |
| 17      | External Retaining Ring            | H5549    | 1   |         |                                    |           |     |

Contact your nearest Coffing Service Center for parts and service. For a complete list, see pages 50 and 51. Please have the hoist model number, serial number, and part number with description available for reference.

## Figure 32 - Trolley Motor, 1-Phase

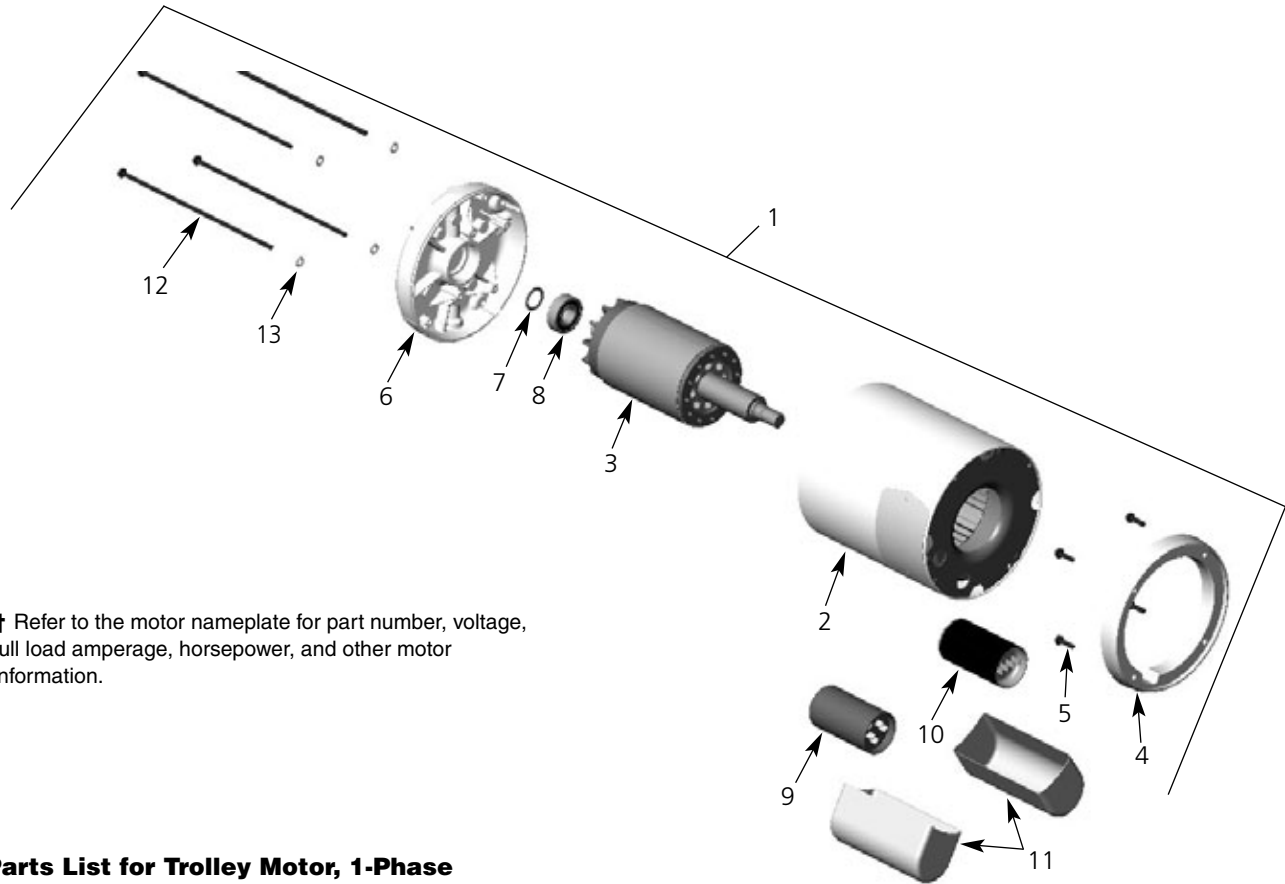

† Refer to the motor nameplate for part number, voltage, full load amperage, horsepower, and other motor information.

### Parts List for Trolley Motor, 1-Phase

| Ref No. | Description                   | Part No.    | Qty | Ref No. | Description                  | Part No.      | Qty |
|---------|-------------------------------|-------------|-----|---------|------------------------------|---------------|-----|
| 1       | Trolley Motor                 |             |     | 10      | SINPAC® Starting Switch      | 839J3         | 1   |
|         | 1/4 hp, 115/230V-1Ph-60Hz     | 861JL11M    | 1   | 11      | Capacitor/Start Switch Cover | 35CB4802A02SP | 2   |
|         | 1/2 hp, 115/230V-1Ph-60Hz     | 861JL12M    | 1   | 12      | Thru Bolt                    | HA3100A80     | 4   |
| 2       | Stator Assembly               | *           | 1   | 13      | #10 Spring Lockwasher        | H4082P        | 4   |
| 3       | Rotor Assembly                | *           | 1   | △       | Capacitor/Start Switch       |               |     |
| 4       | Adapter Ring                  | *           | 1   |         | Cover Insulator              | NS2501A01     | 2   |
| 5       | 10-32NF x 7/8" Mounting Bolts | *           | 4   | △       | Cover Screw                  | H2981P        | 4   |
| 6       | End Shield                    | 35EP3100A04 | 1   |         |                              |               |     |
| 7       | Shim Washer                   | †           | 1   |         |                              |               |     |
| 8       | Rear Bearing                  | 500K3       | 1   |         |                              |               |     |
| 9       | Capacitor                     | JL810-4     | 1   |         |                              |               |     |

△ **Not Shown**

\* **Not available as an individual part. Complete motor must be purchased.**

† **Contact Factory.**

Contact your nearest Coffing Service Center for parts and service. For a complete list, see pages 50 and 51. Please have the hoist model number, serial number, and part number with description available for reference.

## Figure 33 - Trolley Motor, 3-Phase

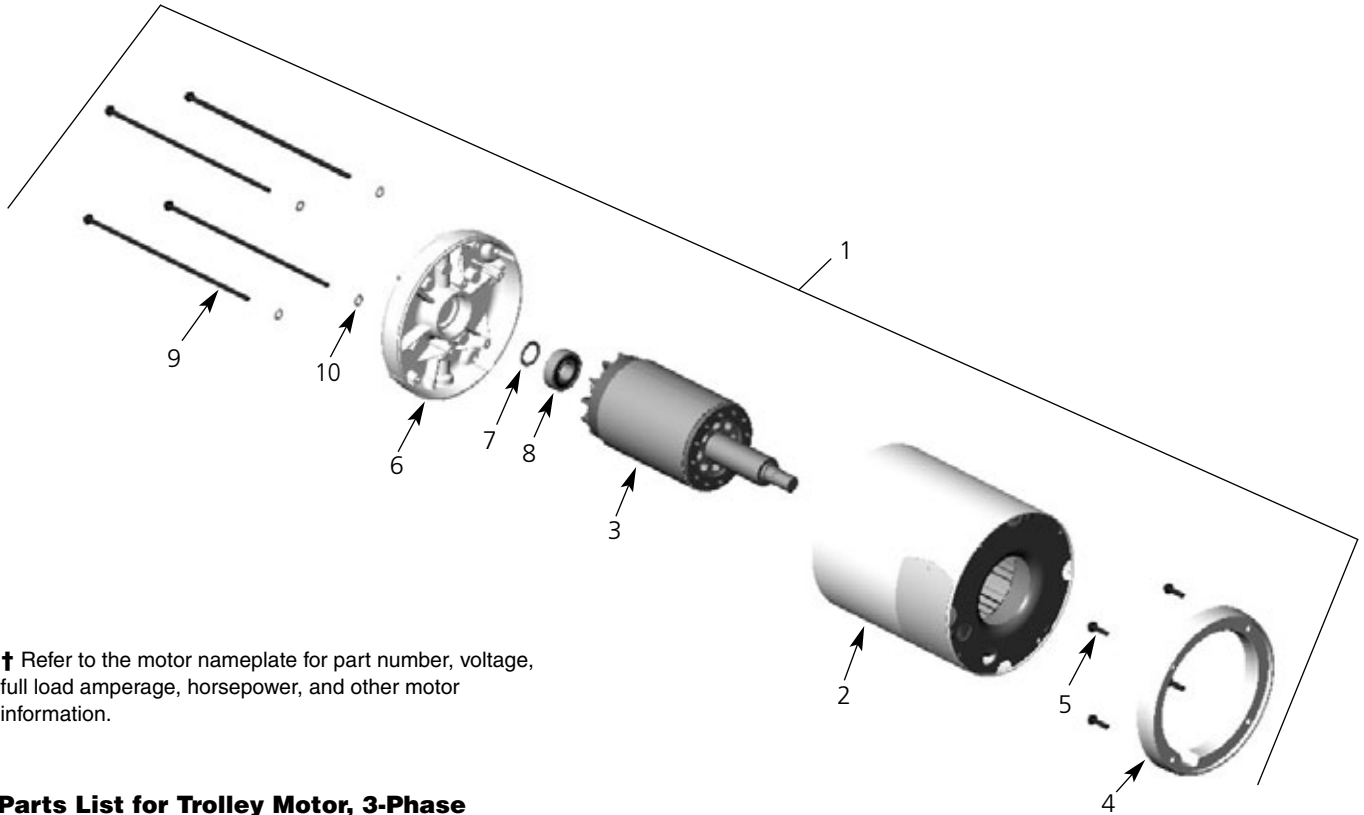

† Refer to the motor nameplate for part number, voltage, full load amperage, horsepower, and other motor information.

### Parts List for Trolley Motor, 3-Phase

| Ref No. | Description                   | Part No. | Qty | Ref No. | Description                   | Part No.    | Qty |
|---------|-------------------------------|----------|-----|---------|-------------------------------|-------------|-----|
| 1       | <b>Trolley Motor, 1-Speed</b> |          |     | 4       | Adapter Ring                  | *           | 1   |
|         | 1/4 hp, 208-230/460V-3Ph-60Hz | 863JL1M  | 1   | 5       | 10-32NF x 7/8" Mounting Bolts | *           | 4   |
|         | 1/2 hp, 208-230/460V-3Ph-60Hz | 863JL2M  | 1   | 6       | End Shield                    | 35EP3100A04 | 1   |
|         | 1/4 hp, 575V-3Ph-60Hz         | 863JL5M  | 1   | 7       | Shim Washer                   | †           | 1   |
|         | 1/2 hp, 575V-3Ph-60Hz         | 863JL6M  | 1   | 8       | Rear Bearing                  | 500K3       | 1   |
|         | <b>Trolley Motor, 2-Speed</b> |          |     | 9       | <b>Thru Bolt, 1-Speed</b>     | HA3100A80   | 4   |
|         | 1/4 hp, 208-230V-3Ph-60Hz     | 873JL1M  | 1   |         | <b>Thru Bolt, 2-Speed</b>     |             |     |
|         | 1/2 hp, 208-230V-3Ph-60Hz     | 873JL2M  | 1   |         | 1/4 hp                        | HA3100A80   | 4   |
|         | 1/4 hp, 460V-3Ph-60Hz         | 873JL5M  | 1   |         | 1/2 hp                        | HA3100A37   | 4   |
|         | 1/2 hp, 460V-3Ph-60Hz         | 873JL6M  | 1   | 10      | #10 Spring Lockwasher         | H4082P      | 4   |
|         | 1/4 hp, 575V-3Ph-60Hz         | 873JL9M  | 1   |         |                               |             |     |
|         | 1/2 hp, 575V-3Ph-60Hz         | 873JL10M | 1   |         |                               |             |     |
| 2       | Stator Assembly               | *        | 1   |         |                               |             |     |
| 3       | Rotor Assembly                | *        | 1   |         |                               |             |     |

\* **Not available as an individual part. Complete motor must be purchased.**

† **Contact Factory.**



Contact your nearest Coffing Service Center for parts and service. For a complete list, see pages 50 and 51. Please have the hoist model number, serial number, and part number with description available for reference.

## Figure 34 - Optional Mounting Arm

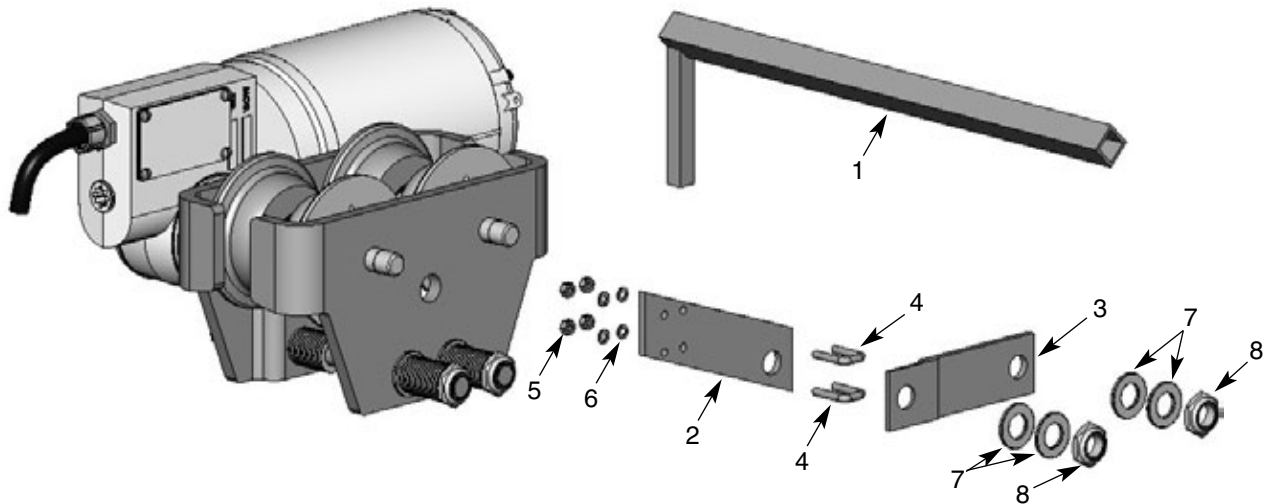
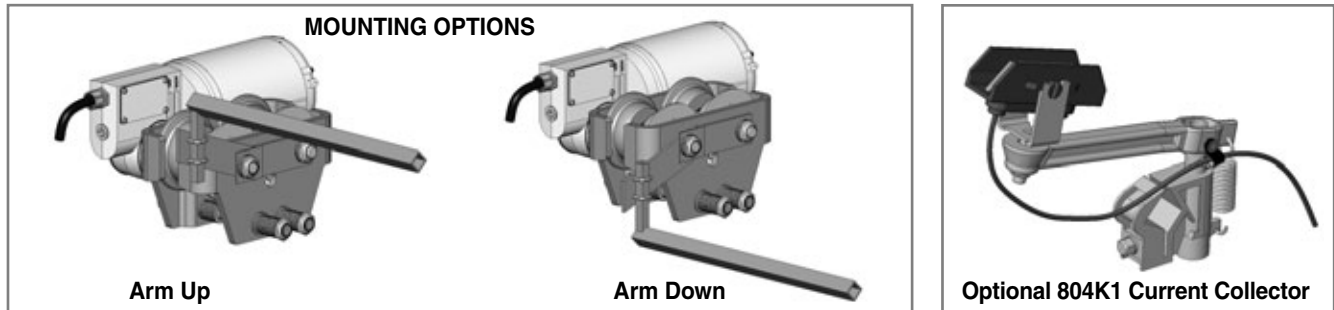

### Parts List for Optional Mounting Arm

| Ref. No. | Description                | Part No. | Qty |
|----------|----------------------------|----------|-----|
| 1        | Mounting Arm               | 803KG8   | 1   |
| 2        | Mounting Plate             | 802K1    | 1   |
| 3        | Brace Plate                | 802K12   | 1   |
| 4        | Shackle                    | 806K1    | 2   |
| 5        | 1/4-20UNC Nut              | H3561P   | 4   |
| 6        | 1/4" Lockwasher            | H4062P   | 4   |
| 7        | 3/4" Flatwasher            | H4211    | 4   |
| 8        | 3/4-16UNF Elastic Stop Nut | H3945    | 2   |

**Note: Arm may be used for mounting current collectors or as a festooning tow arm or similar applications.**

Country Club Road  
P.O. Box 779  
Wadesboro, NC 28170 USA  
**TEL:** (800) 477-5003  
**FAX:** (800) 374-6853

## COFFING AUTHORIZED WARRANTY REPAIR CENTERS AND PARTS DEPOTS

As a Coffing Hoist user, you are assured of reliable repair and parts services through a network of Master Parts Depots and Service Centers that are strategically located across the United States, its territories and Canada. These facilities have been selected on the basis of their demonstrated ability to handle all parts and repair requirements promptly and efficiently.

Below is a list of the Coffing Authorized Warranty Repair Centers and Parts Depots located in United States, its territories and Canada. To quickly obtain the name of a Service Center located nearest you, call (800) 477-5004. Fax: (800) 374-6853. In the following list, the Canadian Service Centers are indicated.

### UNITED STATES

#### ALABAMA

\*\*TOOL SMITH CO.  
1300 4th Ave. S.  
Birmingham AL 35233  
(205) 323-2576 or (800) 317-8665  
Fax (205) 323-9060

#### ARKANSAS

\*\*HI-SPEED HOIST & CRANE  
701 N. Maple St.  
N. Little Rock AR 72114  
(501) 375-9178 Fax (501) 375-4254

\*\*HANDLING SYSTEMS & CONVEYORS INC  
10909 East Otter Creek Rd.  
Mabelville AR 72103  
(501) 455-5898 Fax (501) 455-6179

#### ARIZONA

\*\*MECHANICS TOOL SERVICE  
1301 E. Apache Park Place  
Tucson AZ 85714  
(520) 889-8484 AZ only (800) 372-6700  
Fax (520) 889-6668

#### CALIFORNIA

\*\*ARROW CRANE HOIST CORP.  
12714 South Carmenita Road  
Santa Fe Springs CA 90670  
(562) 921-8328 Fax (562) 921-9307

\*\*IDG. CALIFORNIA  
6842 Walker Street  
LaPalma CA 90623  
(714) 994-6960 or (800) 464-5669  
Fax (714) 521-0105

\*\*CRANWORKS, INC.  
2585 Nicholson Street  
San Leandro CA 94577  
(510) 357-4000 Fax (510) 357-4099

\*\*KIMMERLE BROTHERS, INC.  
12060 East Florence St.  
Santa Fe Springs CA 90670  
(562) 946-6771 Fax (562) 944-3473

\*\*KIMMERLE BROTHERS, INC.  
226 11th St.  
San Francisco CA 94103  
(415) 431-1163 Fax (415) 431-1693

\*\*KIMMERLE BROTHERS, INC.  
337 "M" St.  
Fresno CA 93721  
(559) 233-1278 Fax (559) 233-4678

#### COLORADO

\*\*CRANE REPAIR CO.  
3718 Norwood Drive  
Littleton CO 80125  
(303) 791-7918 or (800) 878-7918  
Fax (303) 791-7179

#### FLORIDA

\*\*J. HERBERT CORP.  
1751 S. John Young Parkway  
Kissimmee FL 32741  
(407) 846-0588 or (800) 255-0588  
Fax (407) 846-8042

\*\*MATERIAL HANDLING SYSTEMS  
720 S.W. 4th Court  
Dania FL 33004  
(954) 921-1171 or (888) 424-6478  
Fax (954) 921-7117

#### GEORGIA

\*\*ACE INDUSTRIES INC.  
6295 McDonough Drive  
Norcross GA 30093  
(770) 441-0898 or (800) 733-2231  
Fax (800) 628-3648

\*GAFFEY INC.  
471 Sessions St.  
Marietta GA 30060  
(770) 939-6443 or (800) 820-6443  
Fax (770) 422-2255

#### ILLINOIS

\*\*INDUSTRIAL TOOL PRODUCTS  
919 N. Central Ave.  
Wooddale IL 60191  
(630) 766-4040 or (800) 525-9654  
Fax (630) 766-4166

\*S & K AIR POWER  
Rt. 316 E., Box 1279  
Mattoon IL 61938  
(217) 258-8500 (IL only-800-955-8501)  
Fax (217) 258-8571

\*\*SIEVERT ELECTRIC SERVICE  
1230 South Hannah  
Forest Park IL 60130  
(708) 771-1600 or (800) 322-9144  
Fax (708) 771-3124

#### INDIANA

\*\*BREHOB CORP.  
1334 S. Meridian St.  
Indianapolis IN 46225  
(317) 231-8080 or (800) 632-4451  
Fax (317) 231-8072

\*\*MATERIALS HANDLING EQUIPMENT  
7433 US 30 East  
Fort Wayne IN 46803  
(219) 749-0475 or (800) 443-6432  
Fax (219) 749-0481

#### IOWA

\*\*ALTER & SONS, INC.  
514 S. Howell St.  
Davenport IA 52808  
(563) 323-3601 or (800) 553-1111  
Fax (563) 324-0138

#### KENTUCKY

\*\*ADVANCED SHERMAN  
330 North Spring St.  
Louisville KY 40206  
(502) 896-2166 (KY only-800-633-8186)  
Fax (502) 897-9837

#### LOUISIANA

\*\*RENTAL SERVICE  
3301 Cities Service Hwy  
West Lake LA 70669  
(337) 882-6011  
Fax (337) 882-0527

\*\*DRILLCO  
12649 S. Choctaw Dr.  
Baton Rouge LA 70815  
(225) 272-8251 or (800) 851-3821  
Fax (800) 315-9225

#### MICHIGAN

\*COMMERCIAL GROUP  
9955 Grand River  
Detroit MI 48204  
(313) 931-6100 or (800) 931-7701  
Fax (313) 491-1753

\*\*CONTINENTAL CRANE & SERVICE CO.  
33681 Groesbeck Hwy.  
Fraser MI 48026  
(586) 293-3870 Fax (586) 293-0017

\*\*STEWART ENGINEERING & SALES  
2140 Aurora Ave.  
Muskegon MI 49442  
(231) 767-2140 Fax (231) 767-2233

#### MINNESOTA

\*\*ELECTRIC MOTOR REPAIR, INC.  
2010 N. 4th St.  
Minneapolis MN 55411  
(612) 522-3318 or (800) 345-0198  
Fax (612) 588-1617

\*\*J & B EQUIPMENT  
8200 Grand Avenue South  
Bloomington MN 55420  
(952) 884-2040 Fax (952) 346-1139

\*\*\*PERFECTION CRANE & HOIST INC.  
201 DeGraff Ave.  
Swanville MN 56382  
(320) 547-2401 or (800) 253-6829  
Fax (800) 353-2254

\*\*TOTAL TOOL SUPPLY  
315 N. Pierce St.  
St. Paul MN 55104  
(952) 646-4055 or (800) 444-4899  
Fax (952) 646-8610

#### MISSOURI

\*\*HERTZ EQUIPMENT RENTAL & SUPPLY  
800 E. 18th St.  
Kansas City MO 64108  
(816) 221-7788 or (800) 669-7788  
Fax (816) 221-0817

\*\*HANDLING SYSTEMS INC.  
11678 Gravois Rd.  
St. Louis MO 63126  
(314) 842-7263 Fax (314) 842-5041

\*\*ZELLER ELECTRIC  
4250 Hoffmeister  
St. Louis MO 63125  
(314) 638-9641 (Outside MO (800) 530-5810)  
Fax (314) 638-6318

#### MONTANA

\*\*POWER SERVICE OF MONTANA, INC.  
4025 1st Ave.  
Billings Montana 59101  
(406) 252-8114 or (800) 823-8665  
Fax (406) 259-3956

#### NEW JERSEY

\*\*SISSCO  
186 Route 206 South  
Hillsborough NJ 08844  
(908) 359-9767 or (800) 392-0146  
Fax (908) 359-9773

UNITED STATES

**NEW YORK**

\*\*ABC ELECTRIC  
24-25 46th Street.  
Long Island City NY 11103  
(718) 956-0000 or (N.Y. only-800-562-1919)  
FAX (718) 956-4455

\*\*BEATON INDUSTRIAL, INC.  
6083 Trenton Rd.  
Utica NY 13502  
(315) 797-9346 (N.Y. only-800-724-4052)  
Fax (315) 797-9321

\*\*VOLLAND ELECTRIC EQUIPMENT CO.  
75 Innsbruck Drive  
Buffalo NY 14227  
(716) 656-9900 Fax (716) 656-8899

**NORTH CAROLINA**

\*\*CAROLINA HOIST  
3310 E. Wendover Avenue  
Greensboro NC 27405  
(336) 375-6050 or (800) 326-3655  
Fax (336) 375-6053

\*\*SOUTHERN ELECTRIC SERVICE  
2225 Freedom Drive  
Charlotte NC 28266  
(704) 372-4832 or (800) 487-3726  
Fax (704) 342-2604

**OHIO**

\*\*CRANE AMERICA - H. W. HOUSE  
920 Deneen Avenue  
Monroe OH 45050  
(513) 539-9770 or (800) 331-5326  
Fax (513) 539-9577

\*\*AMERICRANE & HOIST CORP.  
13224 Enterprise Avenue  
Cleveland OH 44135  
(216) 267-9100 or (800) 652-1932  
Fax (216) 267-9131

\*SAMSEL SUPPLY CO.  
1285 Old River Road  
Cleveland OH 44113  
(216) 241-0333 or (800) 892-8012  
Fax (216) 241-3426

**OKLAHOMA**

\*\*GAFFEY INC.  
9655 E. 522 Road  
Claremore OK 74017  
(918) 343-1191 or (800) 331-3916  
Fax (918) 343-7304

**OREGON**

\*\*GENERAL TOOL & SUPPLY CO.  
2705 N.W. Nicolai  
Portland OR 97210  
(503) 226-3411 or (800) 783-3411  
Fax (503) 778-5518

**PENNSYLVANIA**

\*\*AMERICRANE  
1558 Myers Road  
Indiana PA 15701  
(888) 963-9900 or (724) 479-9100

\*\*GLOBE ELECTRIC CO.  
200 23rd Street  
Pittsburgh PA 15215  
(412) 781-2677 or (800) 850-4440  
Fax (412) 781-1812

\*KEYSTONE CRANE & HOIST CO.  
861 S. Washington Road  
McMurray PA 15317  
(724) 746-5080 Fax (724) 746-5082

**PENNSYLVANIA (cont'd)**

\*\*MCDAL CORP.  
475 East Church Road  
King of Prussia PA 19406  
(610) 277-5484 or (800) 626-2325  
Fax (610) 277-4690

\*\*MORRIS MATERIAL HANDLING  
Tinicum Ind. Park Building E  
10 Industrial Highway MS 80  
Lester PA 19113  
(800) 346-2098  
Fax (610) 521-5907

\*\*REPAIR UNLIMITED  
1730 Rockwell Road  
Abington PA 19001  
(215) 657-3335 or (800) 369-5891  
Fax (215) 784-0343

**RHODE ISLAND**

\*\*MOTORS, HOIST & CONTROLS INC.  
179 Railroad Street  
Woonsocket RI 02895  
(401) 767-4568 Fax (401) 767-4567

**SOUTH CAROLINA**

\*\*ENGINEERED SYSTEMS, INC.  
1121 Duncan-Reidville Road  
Duncan SC 29334  
(864) 879-7438 or (800) 879-7438  
Fax (864) 848-3143

**TENNESSEE**

\*\*HOIST & CRANE CO.  
2508 Perimeter Place  
Nashville TN 37214  
(615) 242-3383 or (888) 464-7811  
Fax (615) 255-4379

\*\*HI-SPEED ELECTRICAL CO.  
3013 Thomas Street  
Memphis TN 38127  
(901) 357-6231 Fax (901) 357-6238

**TEXAS**

\*\*ABEL EQUIPMENT CO., INC.  
3710 Cavalier Drive  
Garland TX 75042  
(972) 272-7706 Fax (800) 272-2235

\*\*GAFFEY, INC.  
4301 Garland Drive  
Ft. Worth TX 76117  
(817) 281-1994 or (800) 284-4233  
Fax (817) 581-7831

\*\*GAFFEY, INC.  
4003 S. County Road 1297  
Odessa TX 79765  
(915) 563-2897 or (800) 733-0006  
Fax (915) 563-4703

\*\*GAFFEY, INC.  
1436 N. Duck Creek Road  
Cleveland TX 77327  
(281) 443-6690 or (800) 233-8179  
Fax (281) 592-6984

\*\*HYDRAULIC EQUIPMENT SER.  
1021 N. San Jacinto Street  
Houston TX 77002  
(713) 228-4073 Fax (713) 228-0931

**UTAH**

\*\*ROCKY MOUNTAIN WIRE ROPE & RIG.  
2421 South 2570 West  
Salt Lake City UT 84119  
(801) 972-4972 or (800) 615-3193  
Fax (801) 974-0621

**VIRGINIA**

\*\*FOLEY MATERIAL HANDLING CO.  
11327 Va. Crane Drive  
Ashland VA 23005  
(804) 798-1343 Fax (804) 798-7843

**WASHINGTON**

\*\*B & J INDUSTRIAL SUPPLY  
5601 1st Avenue S.  
Seattle WA 98108  
(206) 762-4430 or (800) 767-4430  
Fax (206) 762-5329

**WISCONSIN**

\*\*ALFERI INDUSTRIAL SALES & SERVICE  
346 Smith Street  
Neenah WI 54956  
(920) 722-6483 Fax (920) 722-6489

\*LIFT INC.

6667 W. Mill Road  
Milwaukee WI 53218  
(414) 353-5353 or (800) 728-5438  
Fax (414) 353-4444

\*TRESTER HOIST & EQUIPMENT  
W136 N4863 Campbell Dr. Suite 4  
Menomonee Falls WI 53051  
(262) 790-0700 or (800) 234-6098  
Fax (262) 790-1009

CANADA

**ALBERTA**

\*\*KRISTIAN ELECTRIC  
4215-64 Avenue SE  
Calgary Alberta T2C 2C8  
(403) 292-9111

**BRITISH COLUMBIA**

\*\*\*AIR BRAKE REPAIR  
144 W. 5th Avenue  
Vancouver British Columbia V5Y 1H7  
(604) 879-7754

**MANITOBA**

\*\*\*B & B DYNAMO  
575 McTavish Street  
Winnipeg Manitoba R2J 2W5  
(204) 237-6066

**ONTARIO**

\*\*TORONTO ELECTRIC  
72 Crockford Blvd  
Scarborough Ontario M1R 3C4  
(416) 755-7716

\*\*PRO-CRANE HOIST REPAIRS INC.  
2050 Speers Road, Unit 2  
Oakville Ontario L6L 2X8  
(905) 825-2586

**QUEBEC**

\*\*LEGER  
7995 17th Avenue  
Montreal Quebec H1Z 5R2  
(514) 376-3050

\*\*UPTOWN LtEE  
460 Hubert Street  
Laval Quebec H7G 2Y9  
(514) 667-1859

\*PARTS DEPOT & REPAIR CENTERS

\*\*PARTS DEPOT & WARRANTY REPAIR CENTER

\*\*\*PARTS DEPOT

# COFFING® WARRANTY

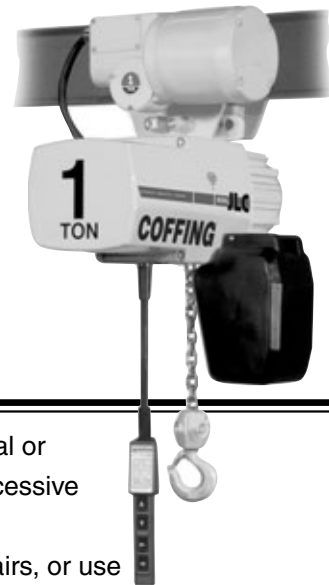

Every hoist is thoroughly inspected and performance tested prior to shipment from the factory. If any properly installed, maintained and operated hoist as outlined in the applicable accompanying Coffing Hoists manual develops a performance problem due to defective materials or workmanship as verified by Coffing Hoists, repair or replacement of the hoist will be made to the original purchaser without charge and the hoist will be returned, transportation prepaid. This warranty does not apply where deterioration is caused by normal wear, abuse, improper or inadequate power supply, improper or inadequate maintenance, eccentric or side loading,

overloading, chemical or abrasive actions, excessive heat, unauthorized modifications or repairs, or use of non-Coffing repair parts. **EXCEPT AS STATED HEREIN, COFFING HOISTS MAKES NO OTHER WARRANTIES, EXPRESS OR IMPLIED, INCLUDING WARRANTIES OF MERCHANTABILITY AND FITNESS FOR A PARTICULAR PURPOSE.**

## **WARNING**

**Overloading and Improper Use Can Result In Injury**

**To Avoid Injury:**

- Do not exceed working load limit, load rating, or capacity.
- Do not use to lift people or loads over people.
- Use only alloy chain and attachments for overhead lifting.
- Read and follow all instructions.

## **COFFING®** HOISTS

**Coffing Hoists • Country Club Road • P.O. Box 779 •  
Wadesboro, North Carolina 28170 USA**

**Tel: 800.477.5003 • Fax: 800.374.6853 • 704.694.6829**

**[www.coffinghoists.com](http://www.coffinghoists.com)**